

PS48.1

MADE IN ITALY

Sistema per armadi con ante scorrevoli sovrapposte

System for wardrobes with overlapping sliding doors

Système pour armoires avec portes coulissantes superposées

System für Schränke mit übereinander liegenden Schiebetüren

Sistema para armarios con puertas corredizas sobrepuestas

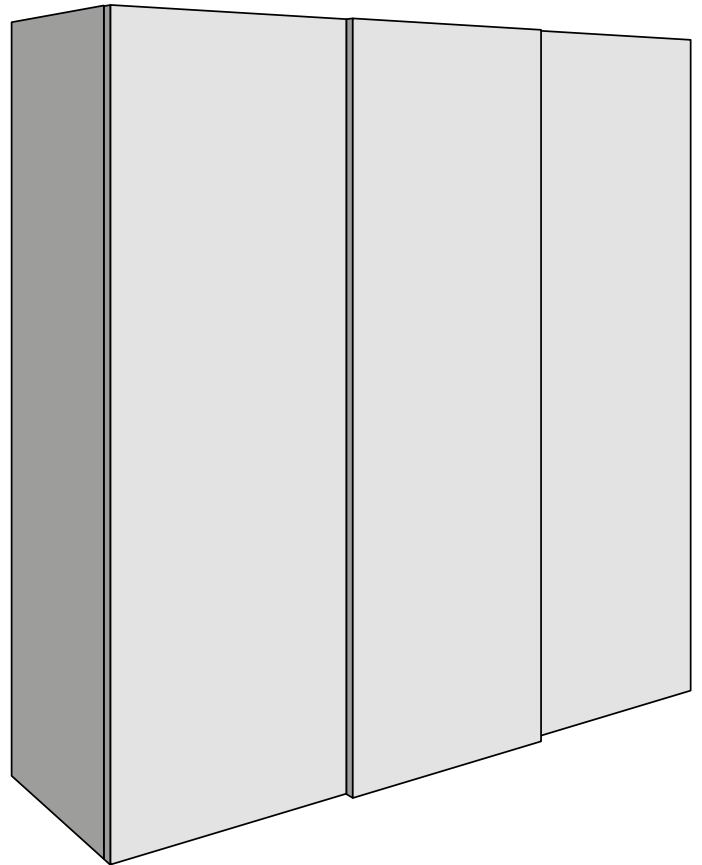
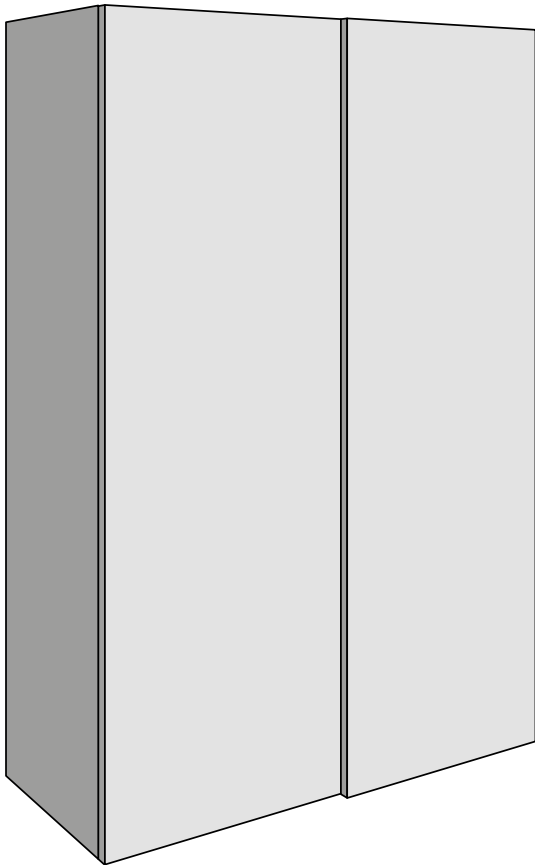

Istruzioni di montaggio

Assembly instructions

Instructions de montage

Montageanleitungen

Instrucciones des ensamblaje



Italiano

Tutte le misure espresse in questo opuscolo sono in millimetri.

ATTENZIONE

Non utilizzare spray ed oli anti frizione o sblocca filetti sui cuscinetti o sulle ruote con O-ring dei pattini scorrevoli. Questo provoca lo scioglimento dei grassi dei cuscinetti rendendoli rumorosi oppure la rottura dell'O-ring.

ABBREVIAZIONI

W	larghezza
WA	larghezza anta
L	lunghezza
LB	lunghezza binario
D	profondità
H	altezza
I	interasse
T	spessore
S	sormonto

Le illustrazioni e le descrizioni di questo opuscolo si intendono fornite a titolo indicativo. L'azienda si riserva pertanto di apportare, in qualsiasi momento e senza preavviso, quelle modifiche che ritenesse utili per qualsiasi esigenza di carattere costruttivo e commerciale.

Deutsch

Alle Maße in diesem Katalog sind in Millimetern.

ACHTUNG

Kein Spray, Schmiermittel oder Lösen-mittel auf die Kugellager und Rollen mit O-Ring der Laufwagen verwenden. Das kann die Kugellager und die Rollen geräuschvoller machen und kann den O-Ring Abriss verursachen.

ABKÜRZUNGS

W	Breite
WA	Türbreite
L	Länge
LB	Länge Schienen
D	Tiefe
H	Höhe
I	Abstand zwischen den Zentren
T	Dicke
S	Überlappung

Die Bilder und Beschreibungen dieses Prospektes sind nur zur Information gegeben. Die Firma kann, in jedem Moment, Änderungen und Verbesserungen ohne Vorankündigung vornehmen.

English

All dimensions in this leaflet are stated in millimeters.

WARNING

Do not use any anti-friction oil or grease or thread-realse spray on ball bearing or on wheels with O-ring, it can cause the melting of the inside ball bearing grease, making them noisy or causing the break of the O-ring of the wheels.

ABBREVIATIONS

W	width
WA	door width
L	length
LB	rail length
D	depth
H	height
I	distance between centres
T	thickness
S	overlapping

The pictures and descriptions this leaflet contains are supplied for information purposes. The company reserves the right to introduce those modifications it deems opportune for any construction or commercial need at any time and without advance notice.

Español

Todas las dimensiones en este folleto se expresan en milímetros.

ADVERTENCIA

No utilices spray y aceites anti-fricción sobre los cojinetes de bolas y sobre las ruedas con O-ring de los patines. Esto puede provocar mayor rumorosidad de los cojines o la rotura de los O-ring.

ABREVIACIONES

W	anchura
WA	anchura de la puerta
L	longitud
LB	longitud de la guía
D	profundidad
H	altura
I	distancia entre centros
T	espesor
S	superposición

Las imagines y las descripciones de este folleto solo se fechas a título informativo. La empresa puede aportar, en cualquier momento y sin preaviso, las modificaciones que cree necesarias por exigencias técnicas y comerciales.

Français

Toutes les mesures indiquées dans cette brochure sont en millimètres.

AVERTISSEMENT

Ne pas utiliser de spray ni d'huile anti frottement ou pour débloquer les filets sur les coussinets ou sur les roulettes avec bague torique des patins coulissants. Ce qui ferait fondre la graisse des roulements en les rendant bruyants ou provoquerait la rupture de la bague torique.

ABRÉVIATIONS

W	largeur
WA	largeur de la porte
L	longueur
LB	longueur de le rail
D	profondeur
H	hauteur
I	entraxe
T	épaisseur
S	chevauchement

Les images et les descriptions de cette notice ne sont fournies qu'à titre indicatif. Le fabricant se réserve donc le droit d'apporter toutes les modifications qu'il jugera utiles à des fins techniques et commerciales à n'importe quel moment et sans aucun préavis.

Lavorazioni richieste per le ante

Working requests for the doors

Usinage nécessaire pour les portes

Verarbeitungsanforderungen für die Türen

Laboreo necesario para las puertas

1

option

1

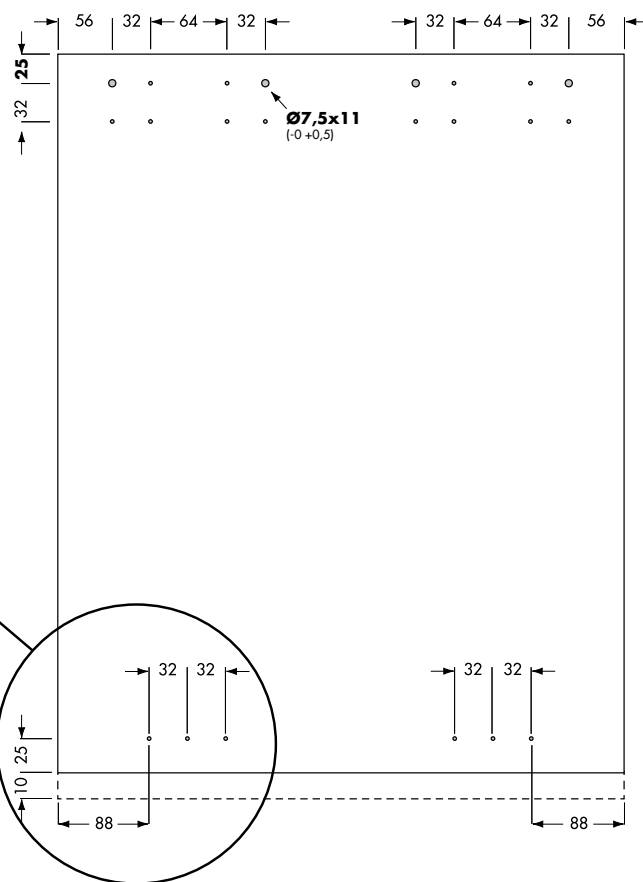
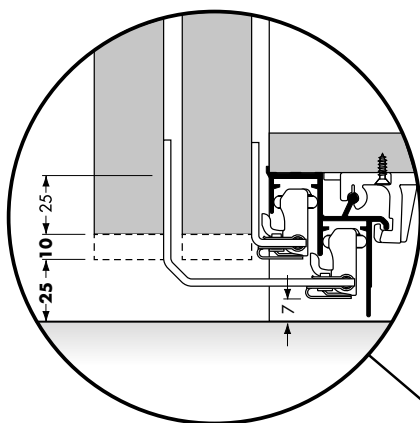
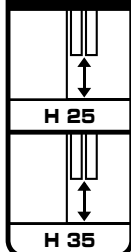

2

option

2

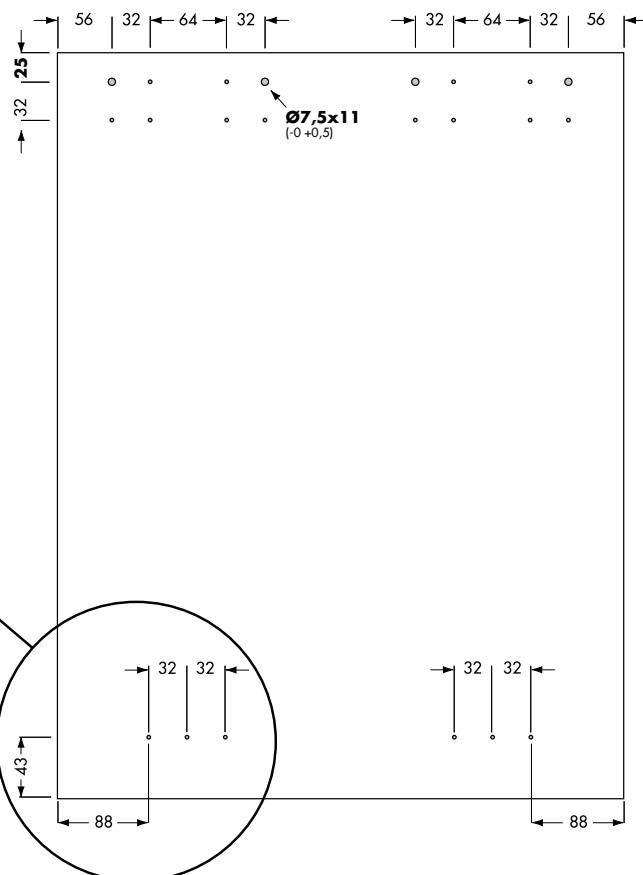
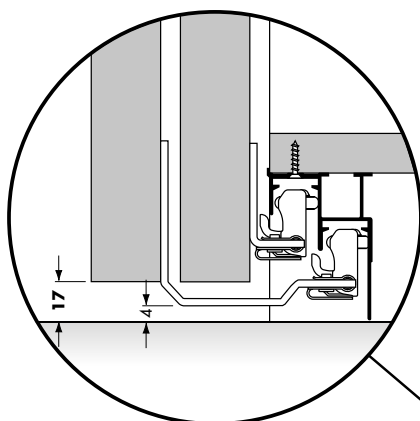
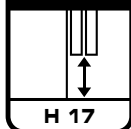

Istruzioni di montaggio

Assembly instructions

Instructions de montage

Montageanleitungen

Instrucciones de ensamblaje



Scegliere il tipo di binario superiore / Choose the type of upper rail /
Choisissez le type de rail supérieur / Wählen Sie den Typ der oberen Schiene / Elija el tipo de guía superior

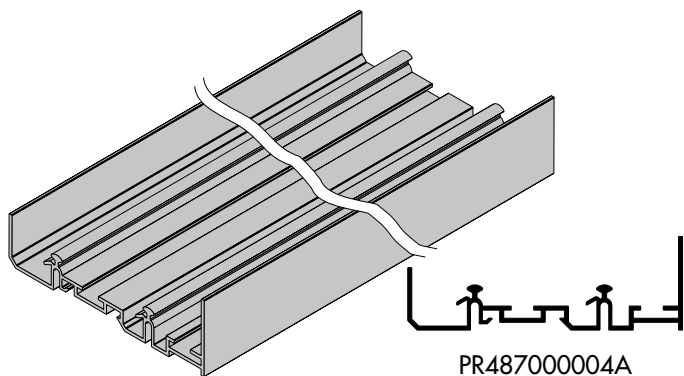

PR487000004A

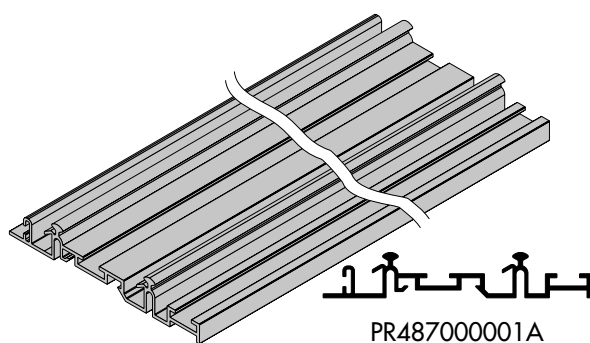

PR487000001A

Fissare il binario superiore al mobile secondo la modalità scelta: 1a, 1b, 1c, 1d.

Fix the upper rail to the wardrobe according to your choice: 1a, 1b, 1c, 1d.

Fixer le rail supérieur au meuble selon le mode choisi: 1a, 1b, 1c, 1d.

Befestigen Sie die obere Schiene an den Schrank nach der gewählten Methode: 1a, 1b, 1c, 1d.

Fijar la guía superior al mueble según vuestra elección: 1a, 1b, 1c, 1d.

1a

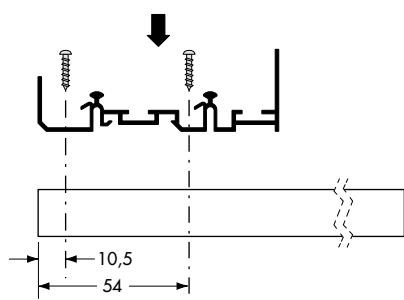

1b

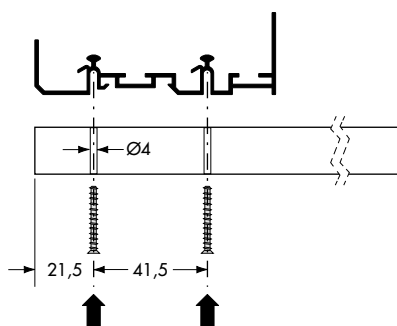

1c

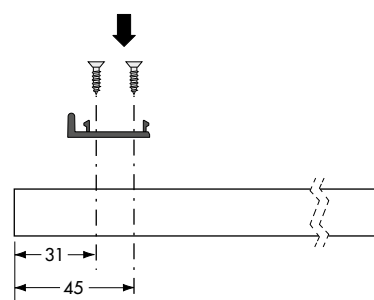

1d

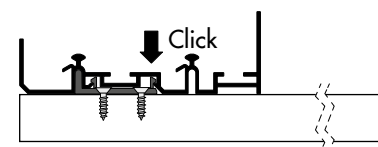
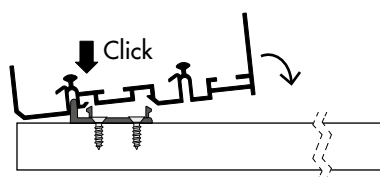
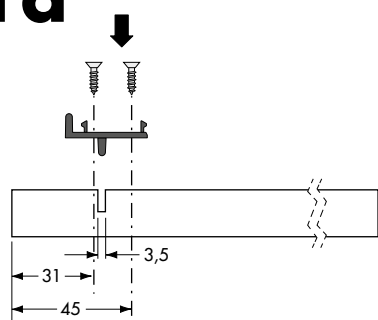

2

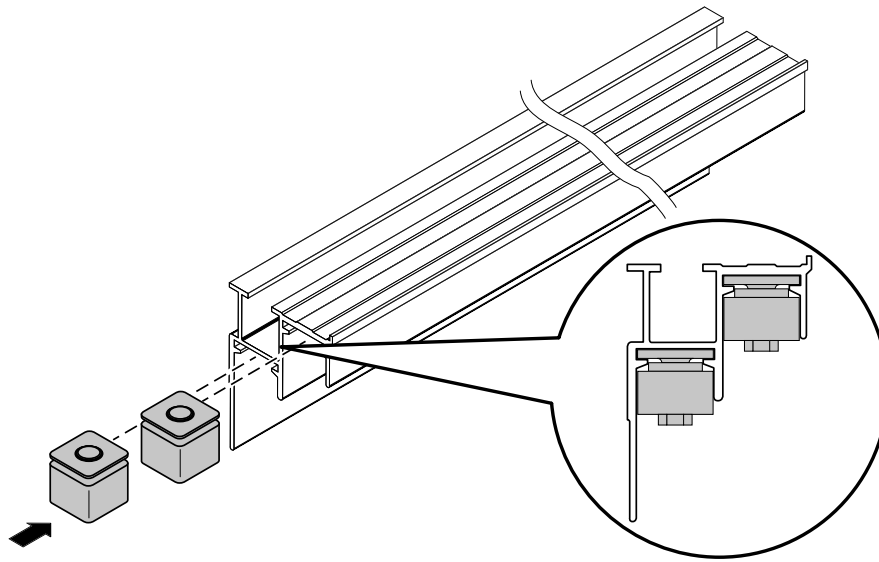

Fissare il binario inferiore al mobile secondo la modalità scelta: 3a, 3b, 3c, 3d.

Fix the lower rail to the wardrobe according to your choice: 3a, 3b, 3c, 3d.

Fixer le rail inférieur au meuble selon le mode choisi: 3a, 3b, 3c, 3d.

Befestigen Sie die untere Schiene an den Schrank nach der gewählten Methode: 3a, 3b, 3c, 3d.

Fijar la guía inferior al mueble según vuestra elección: 3a, 3b, 3c, 3d.

3a

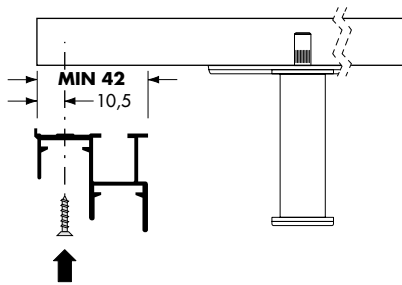

3b

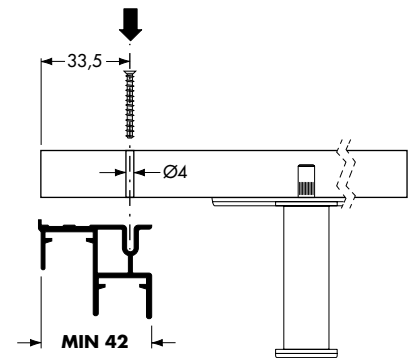

3c

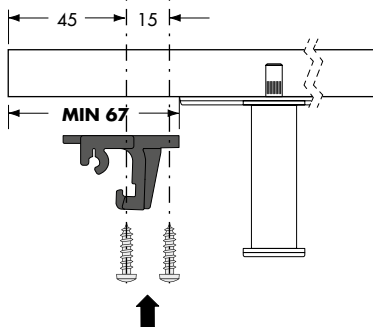

3d

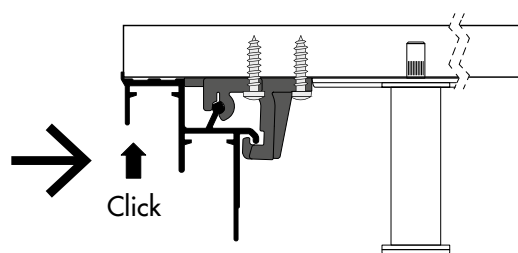
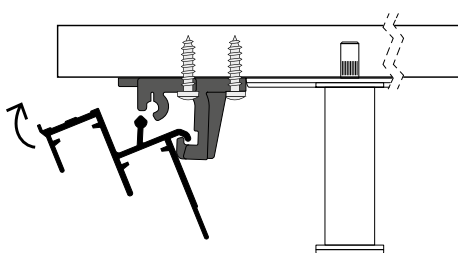
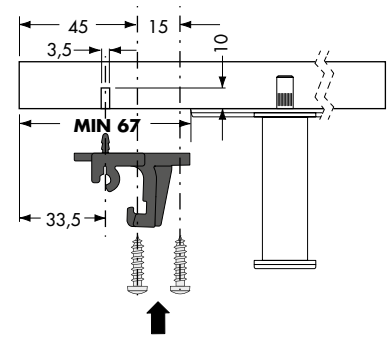



Schemi posizionamento fermi superiori

Positioning of the upper locks

Positionnement des butées supérieurs

Positionierung der obere Aufschläge

Posicionamiento de los topes superiores

A

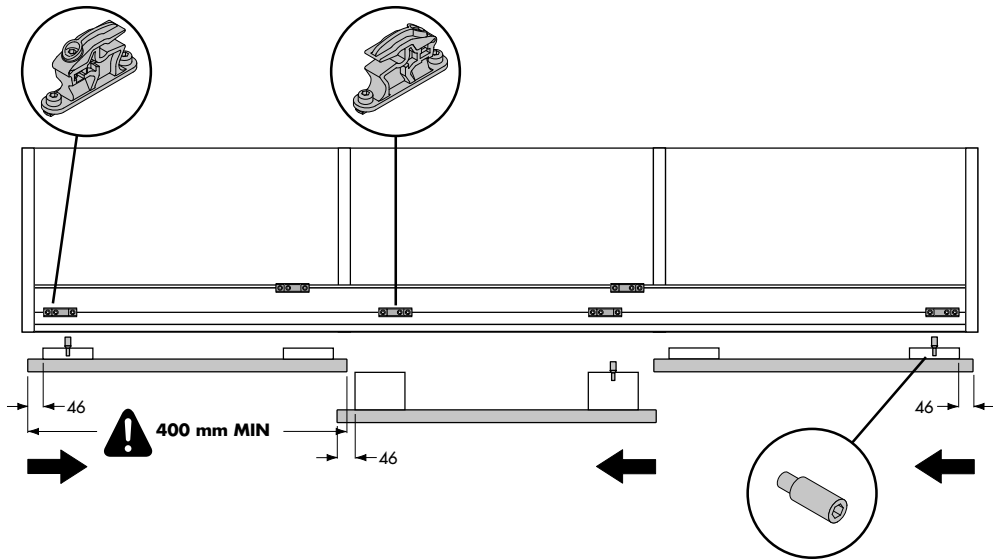

B

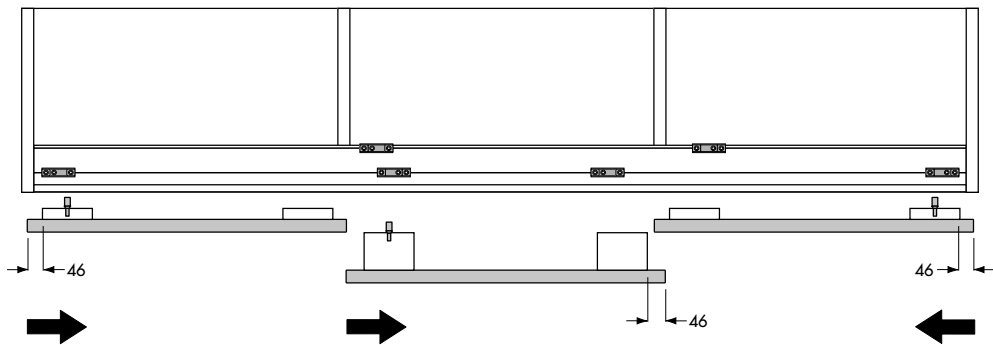

C

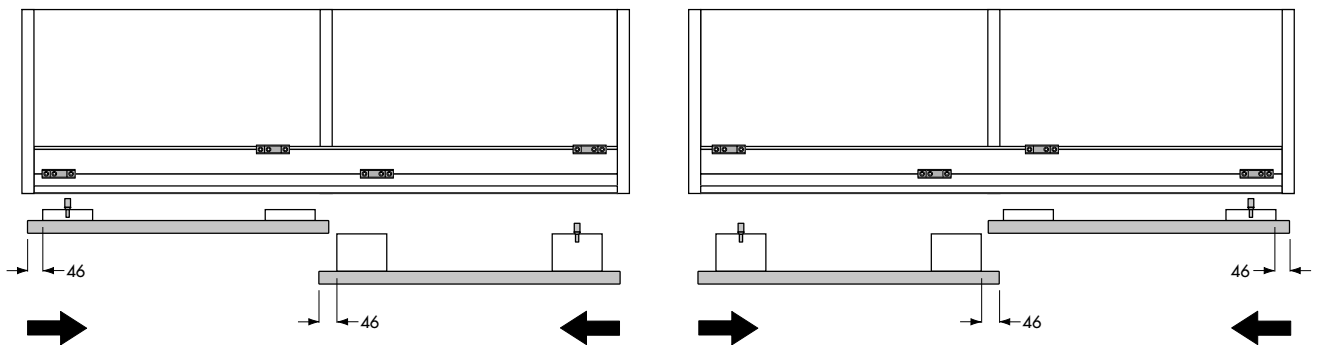

4a

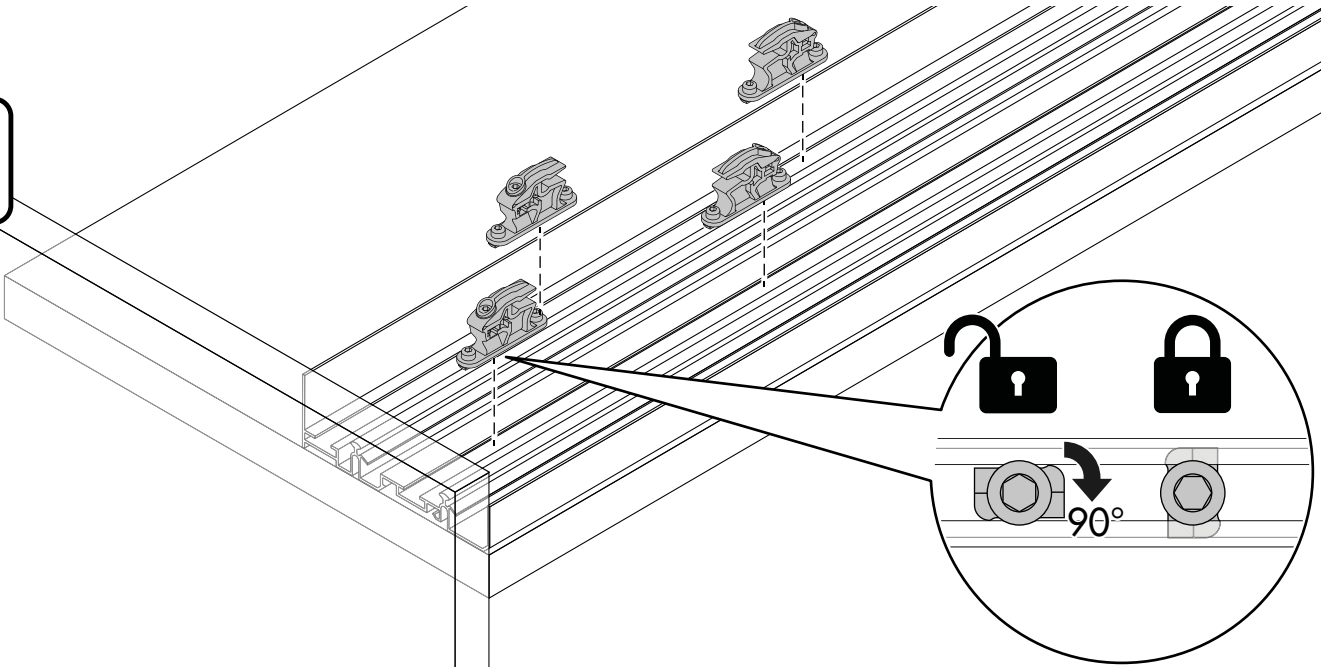

Sistema di fissaggio dall'alto.

Locking system from the top.

Système de fixation par le haut.

Befestigungssystem von der Spitze.

Sistema de fijación desde la parte superior.

5a

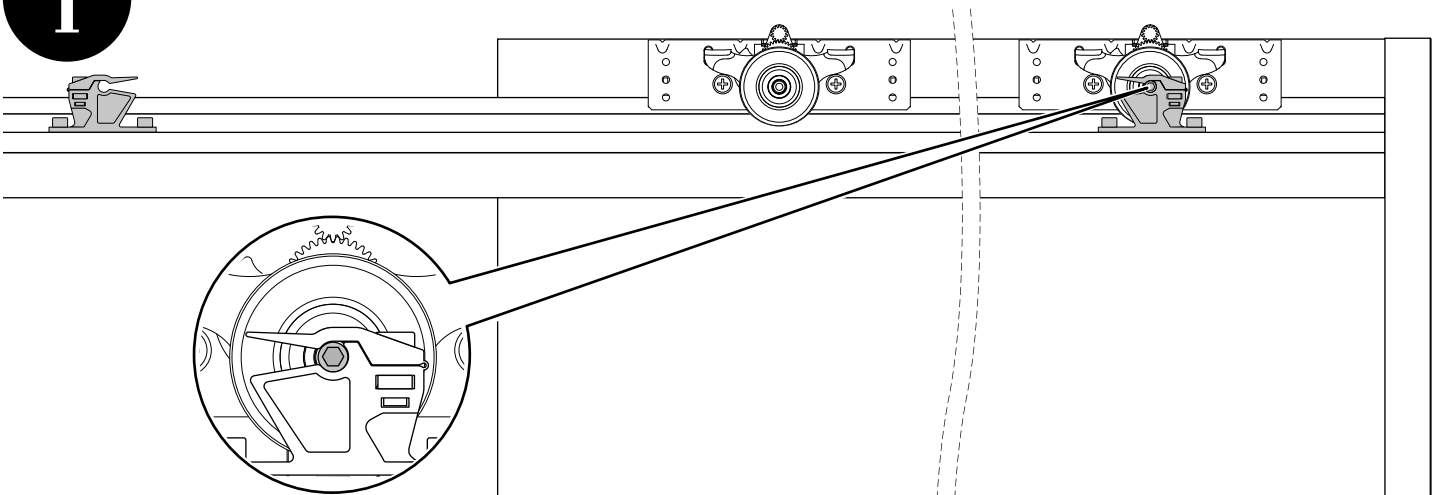
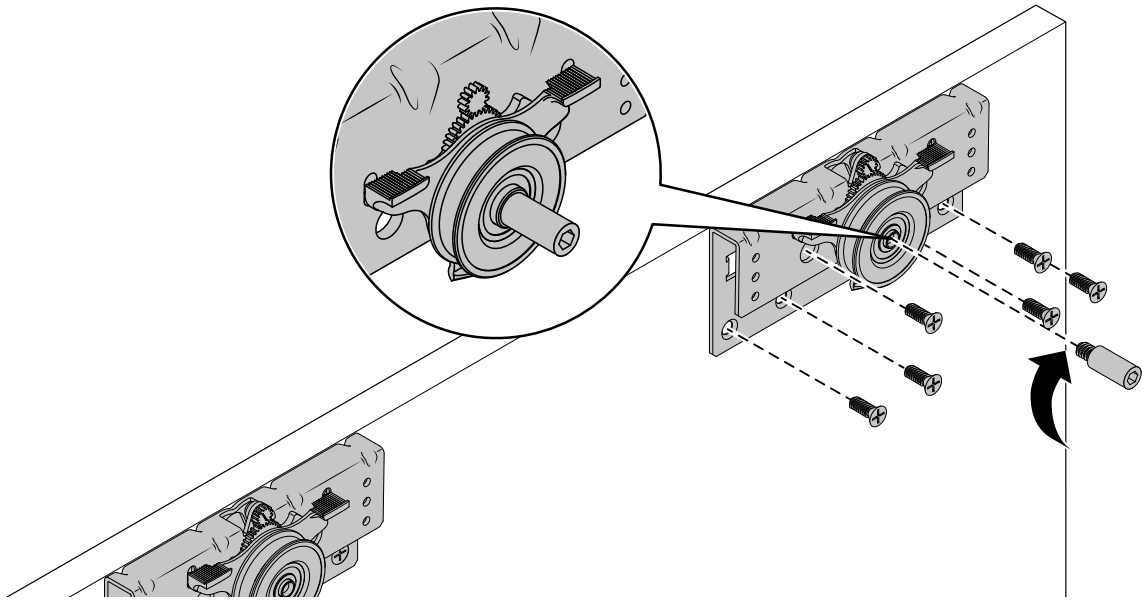

6a

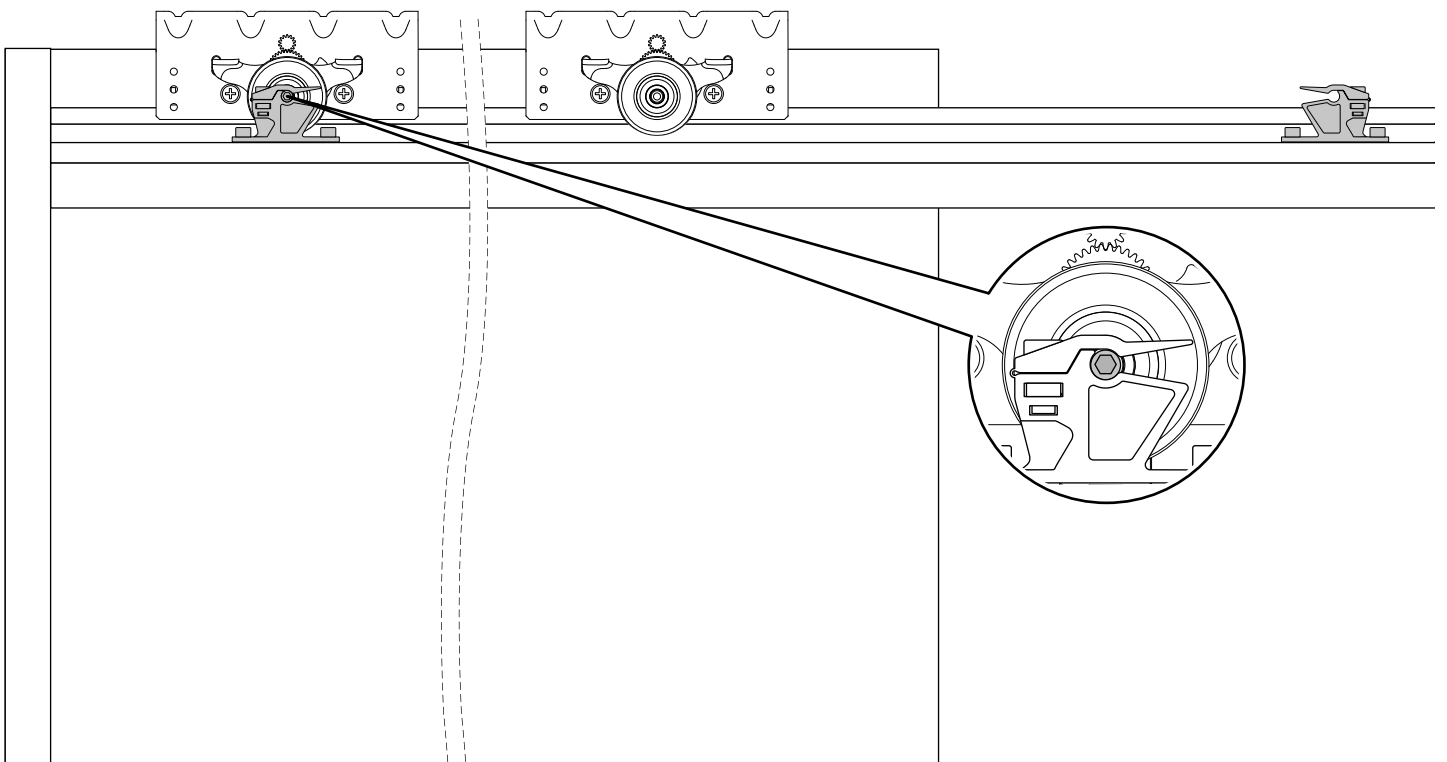
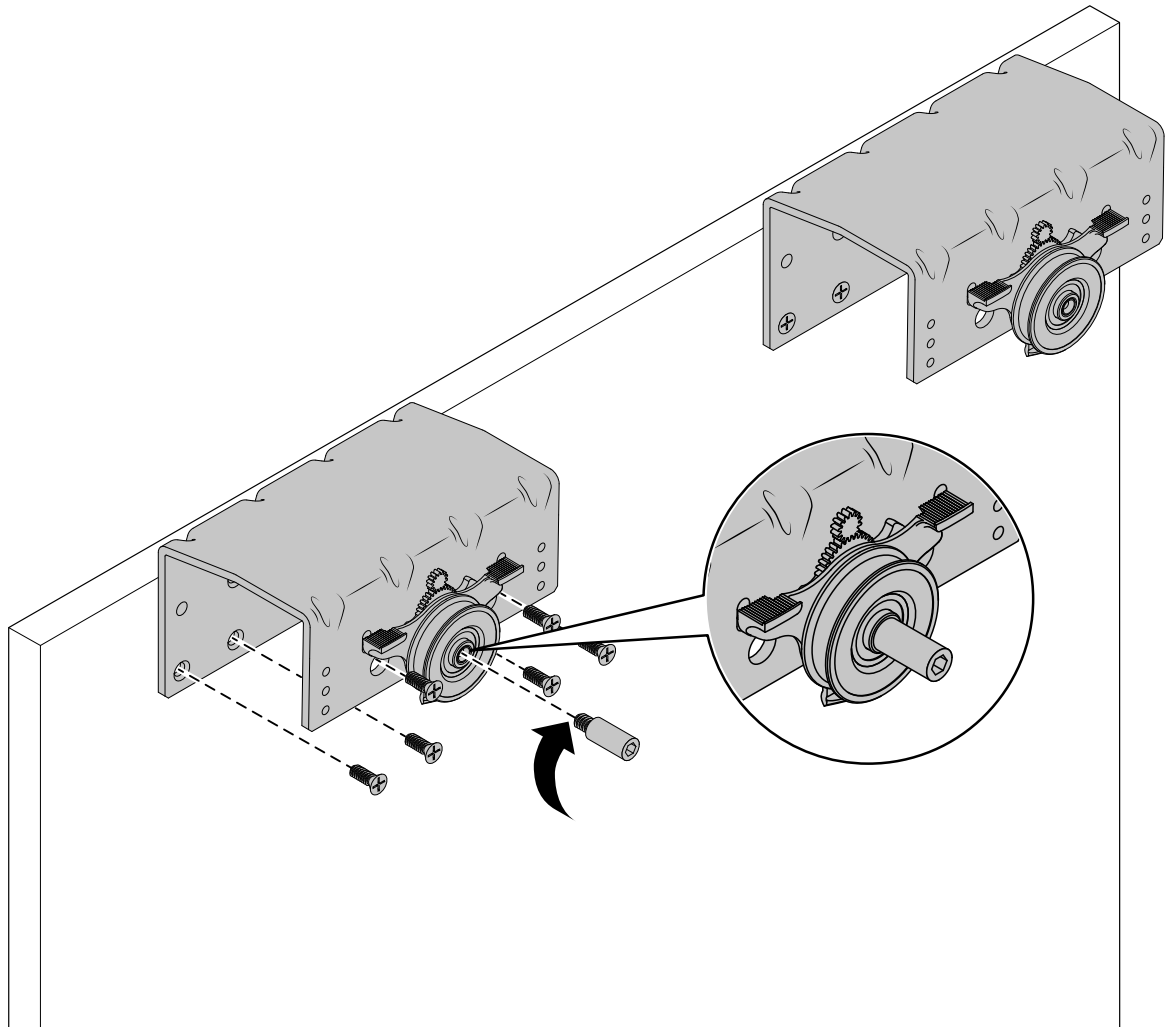

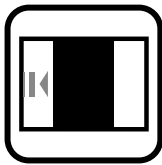

Schemi posizionamento ammortizzatori e attivatori.

Positioning of soft-closing device and activators.

Schémas de positionnement système amortissement et activateurs

Schemen zur Positionierung des Dämpfungssystems und der Aktivatoren.

Esquemas de colocación del sistema de amortización y activadores.

A

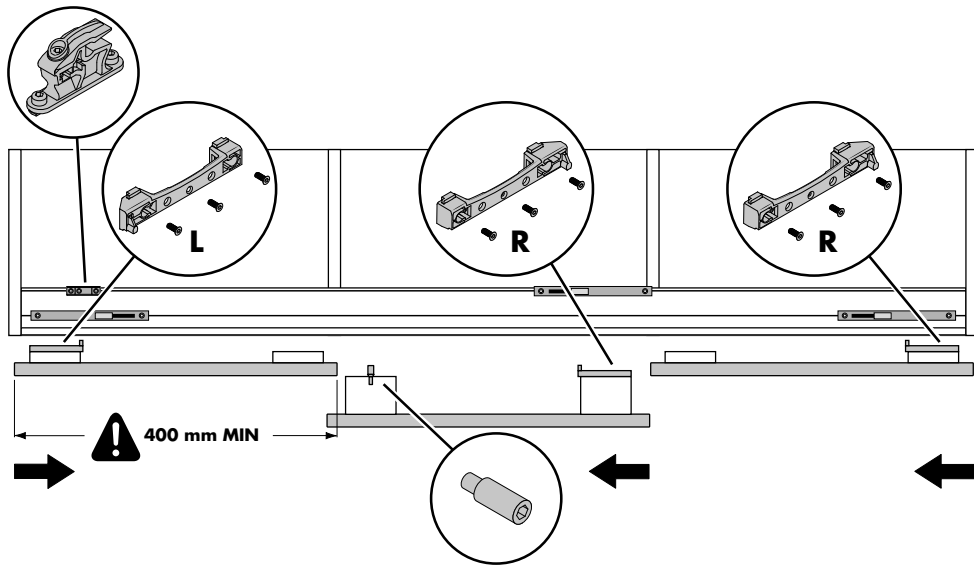

B

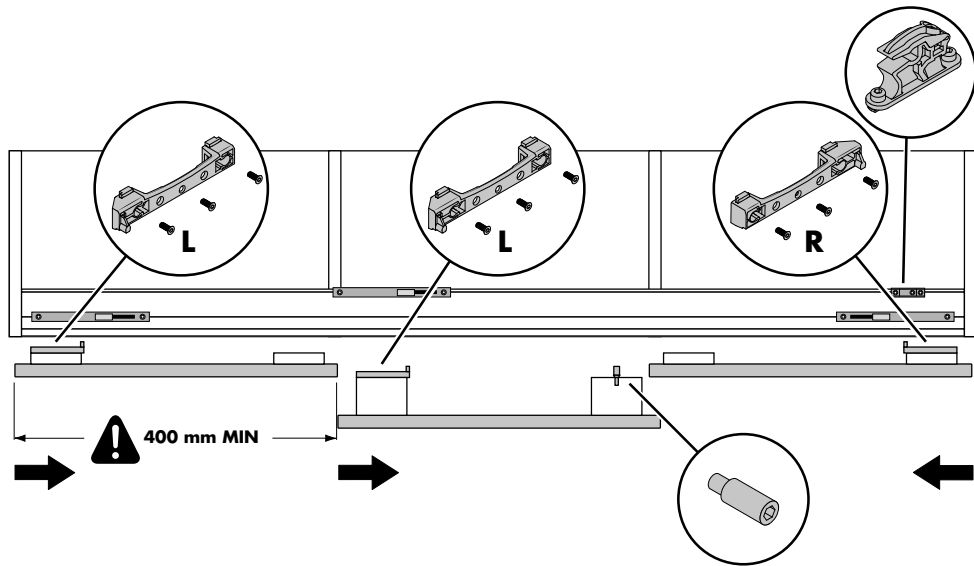

C

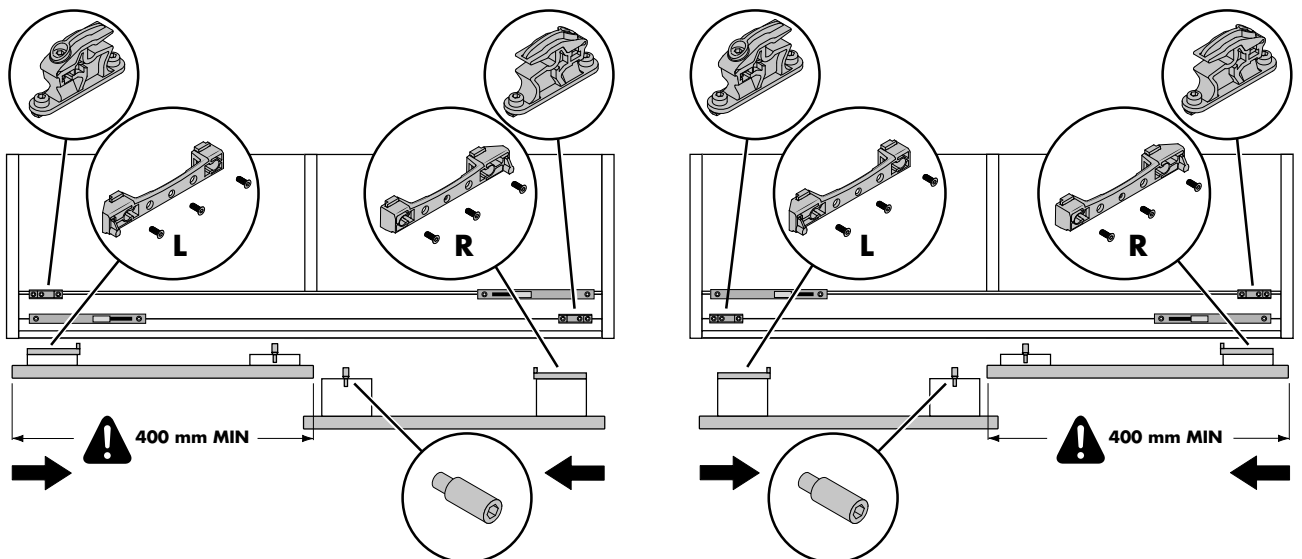



EASY
line



Schemi posizionamento ammortizzatori e attivatori.

Positioning of soft-closing device and activators.

Schémas de positionnement système amortissement et activateurs

Schemen zur Positionierung des Dämpfungsystems und der Aktivatoren.

Esquemas de colocación del sistema de amortización y activadores.

A

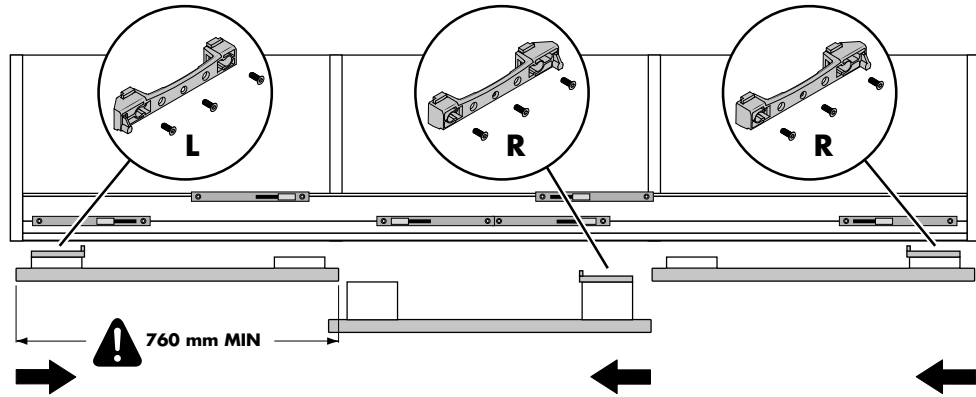

B

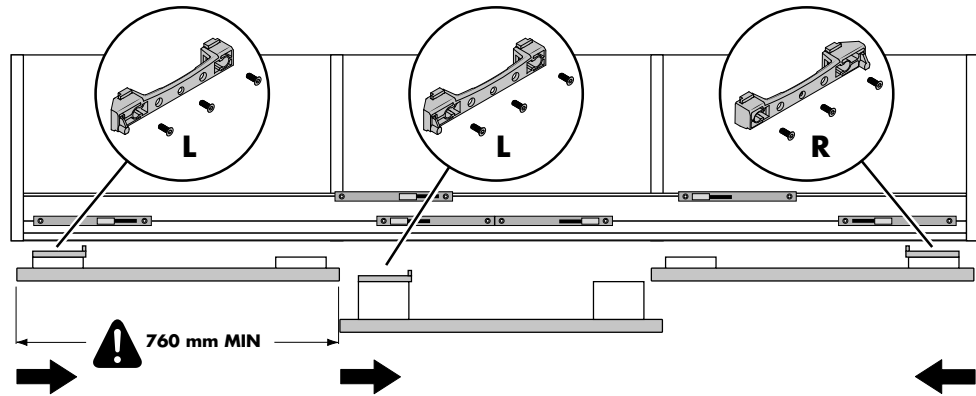

C

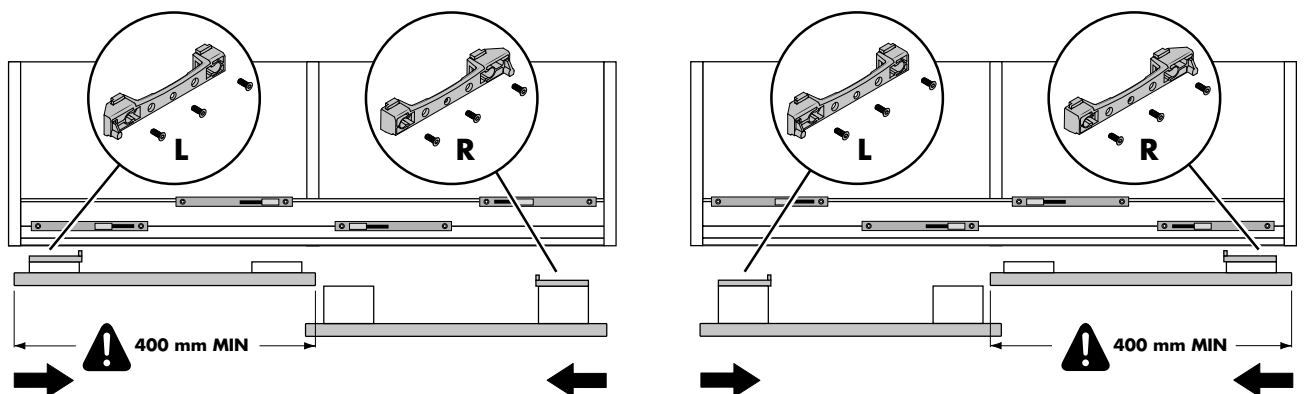

4b

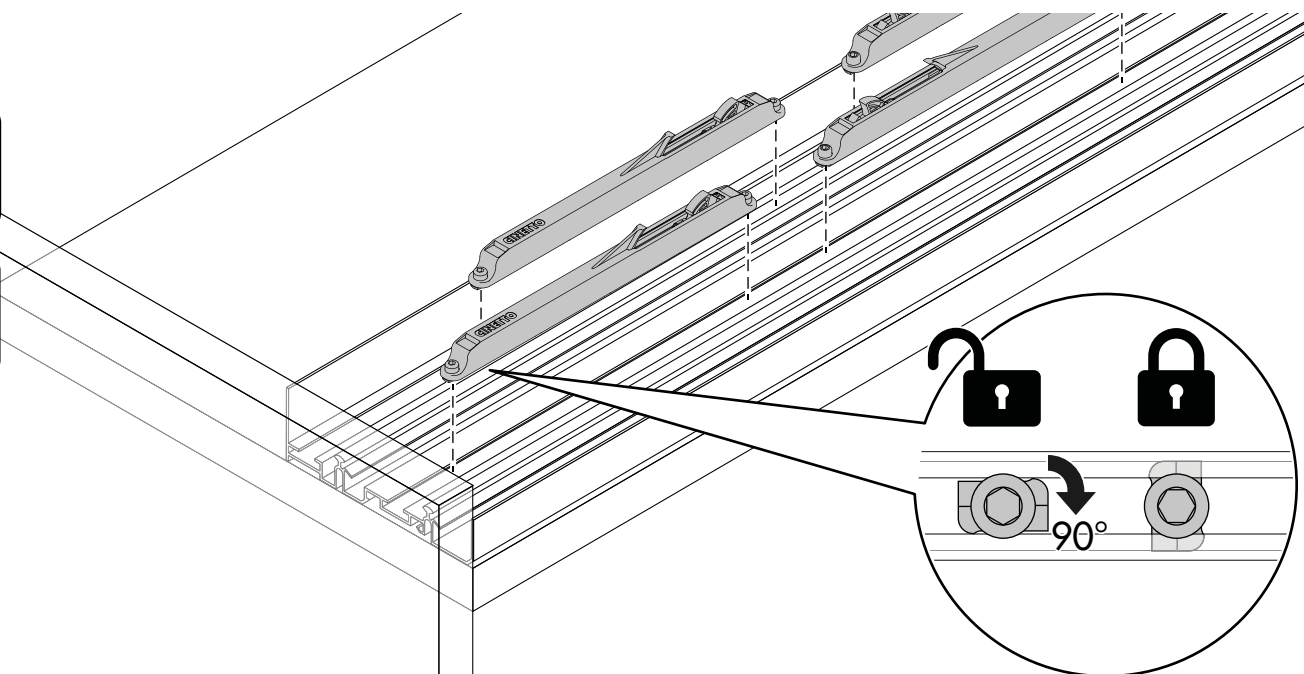
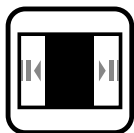

Sistema di fissaggio dall'alto.

Locking system from the top.

Système de fixation par le haut.

Befestigungssystem von der Spitze.

Sistema de fijación desde la parte superior.

5b

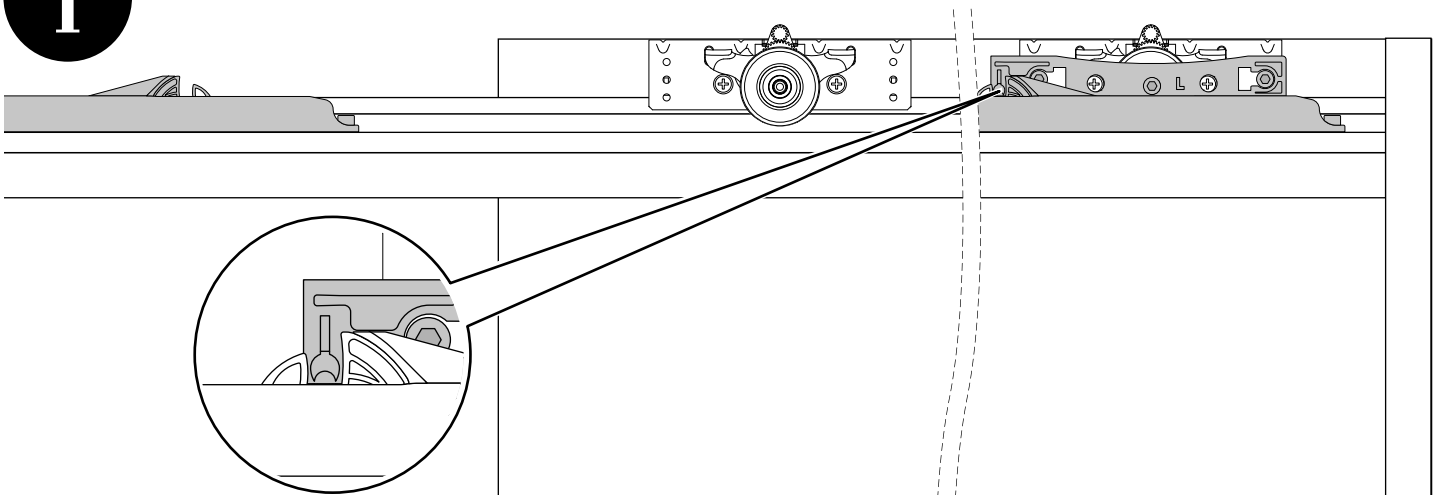
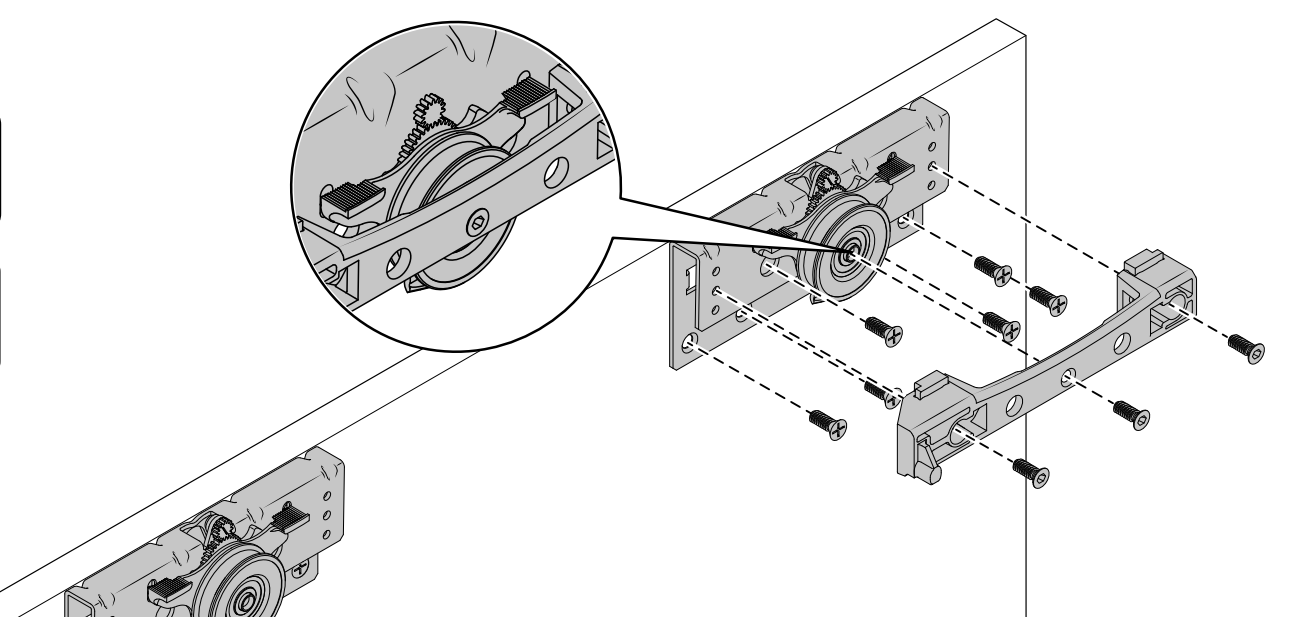

6b

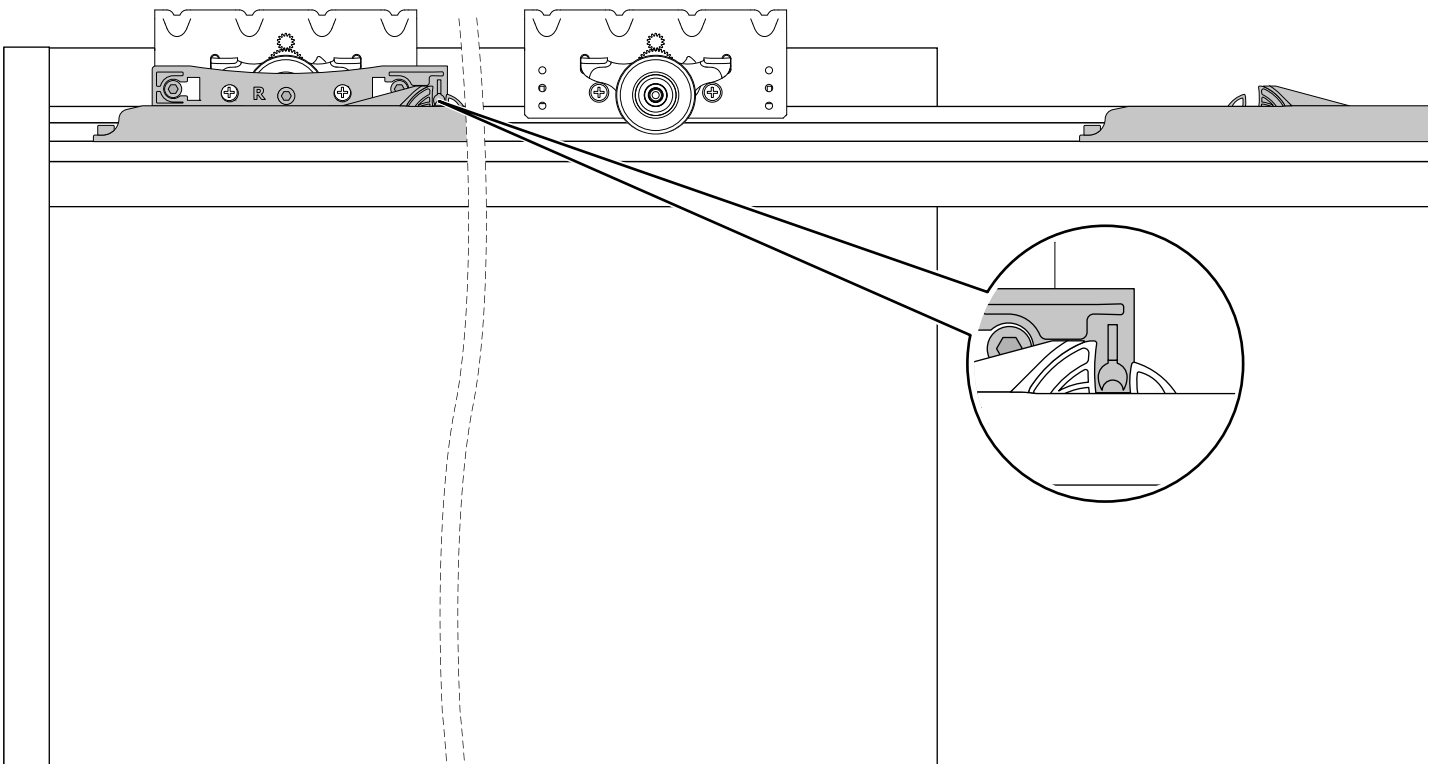
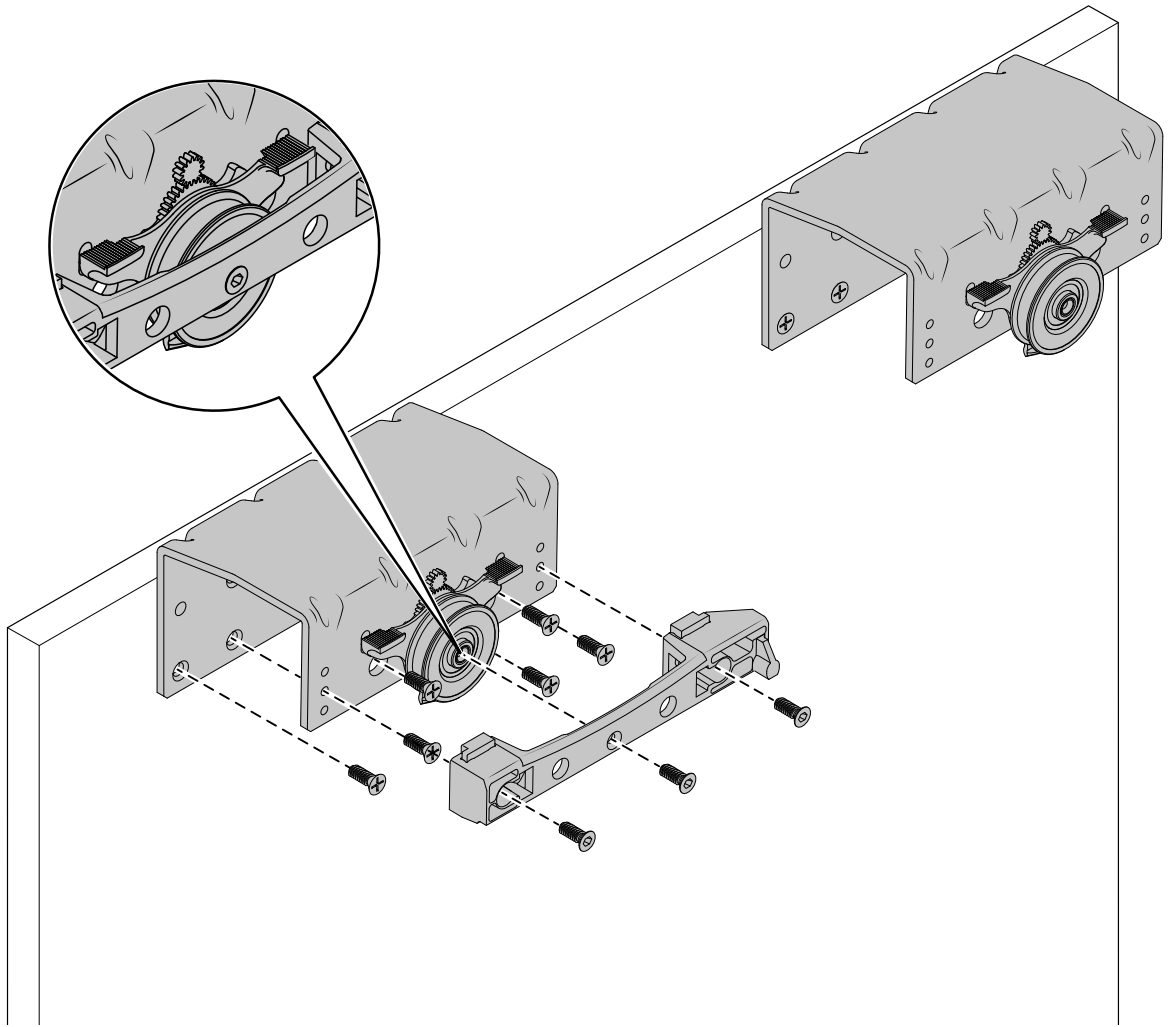
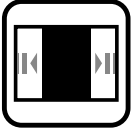

7

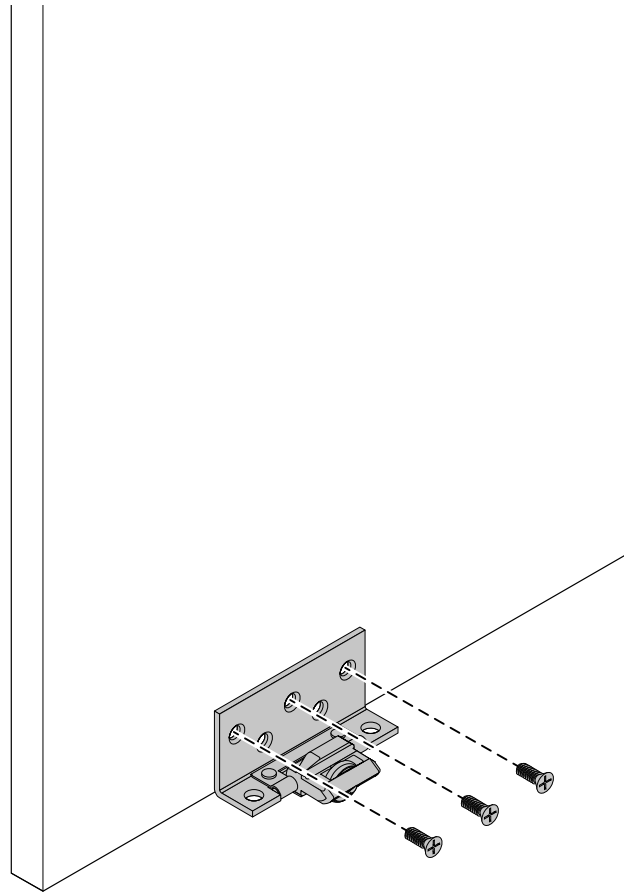

option

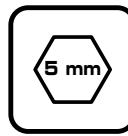

DISTANZIATORE PER ANTE / DOORS
SPACER / ENTRETOISE POUR PORTES /
SPACER FÜR TÜREN / ESPACIADOR PARA
PUERTAS

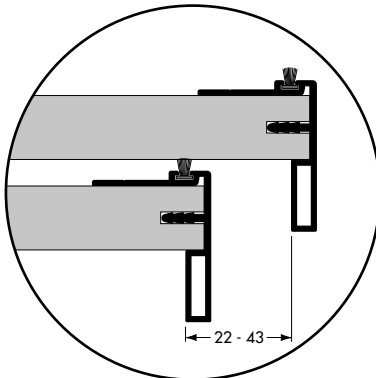
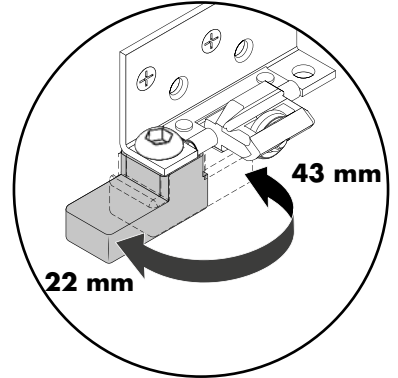
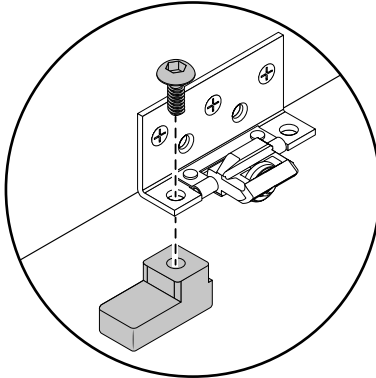

8

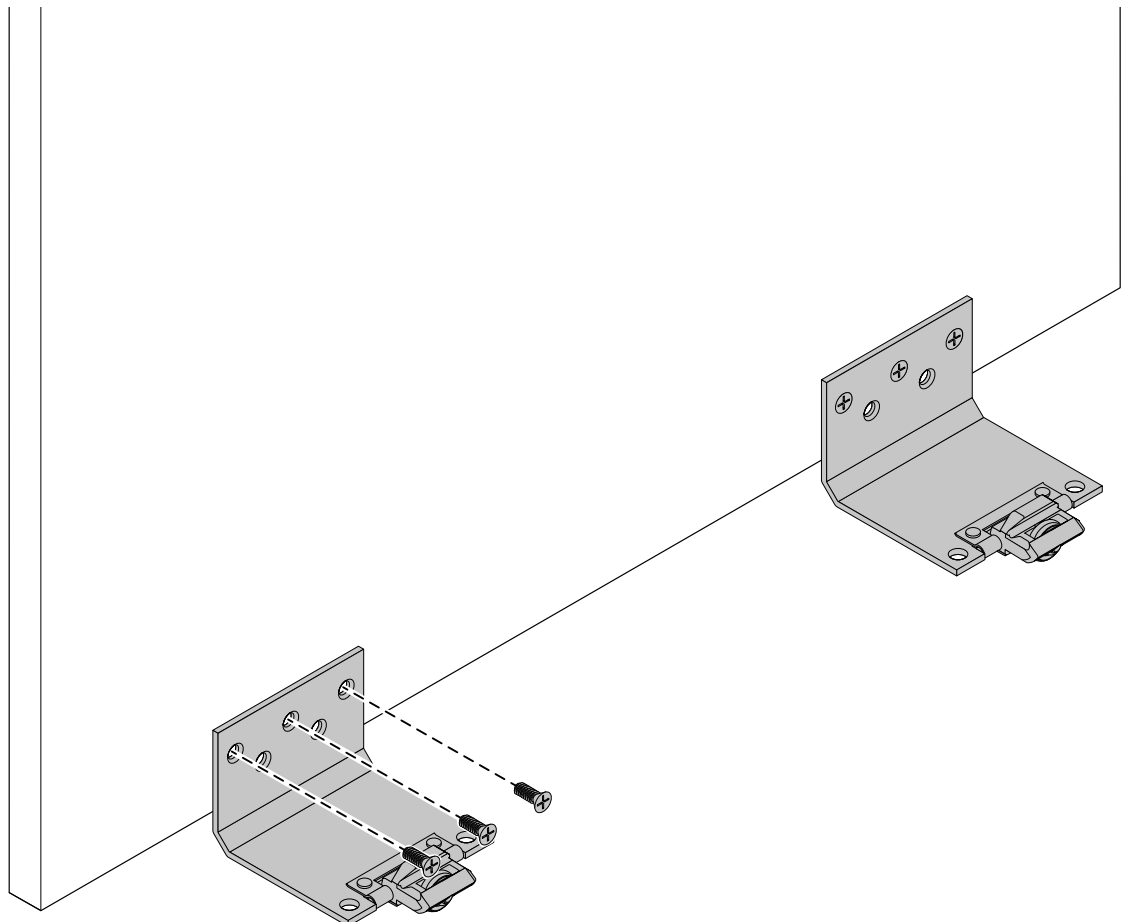

9 PARACOLPI PER SOLA ANTA INTERNA SX - UTILIZZO CON ARMADIO A 3 ANTE

BUMPERS ONLY FOR LEFT INTERNAL DOOR - USABLE WITH 3 DOORS WARDROBE

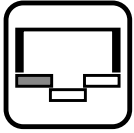

BUTOIR POUR UNE PORTE INTÉRIEUR GAUCHE - À UTILISER AVEC ARMOIRE 3 PORTES

ANSCHLAG NUR FÜR DIE LINKE TÜR - VERWENDET NUR FÜR DIE DREITÜRIGEN SCHRANK

PARAGOLPE PARA LA PUERTA INTERNA - USO EN ARMARIOS DE 3 PUERTAS

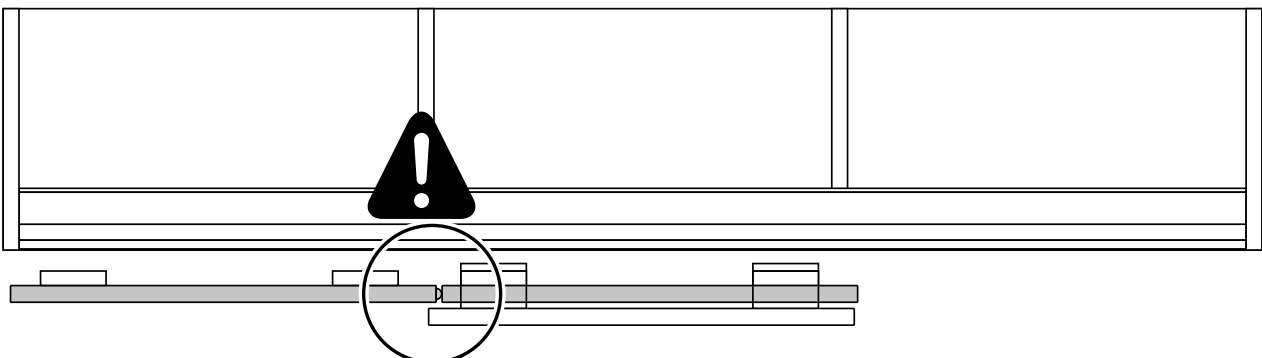
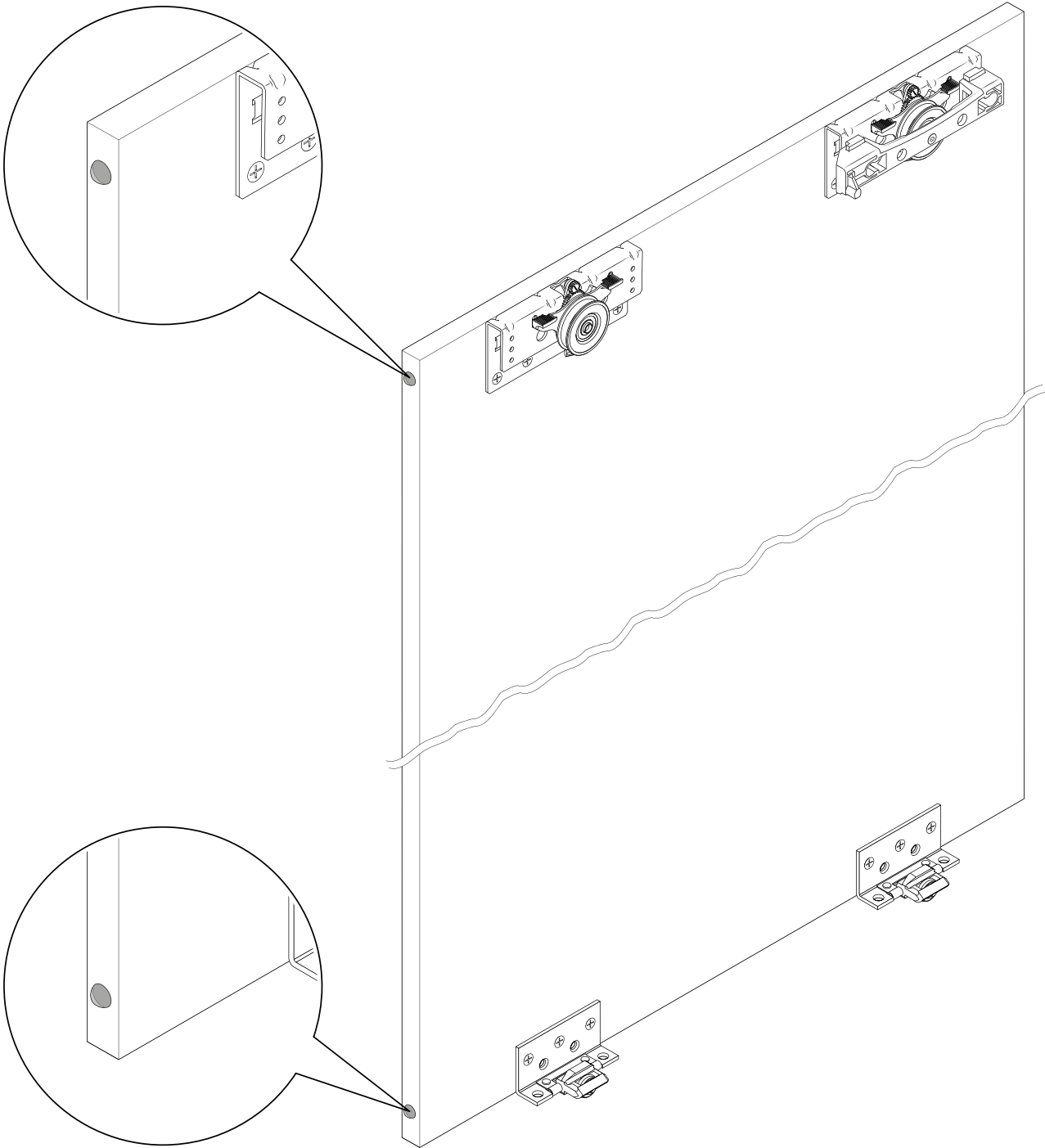

NO

Anta regolata troppo in alto.

Door adjusted too high.

Porte réglé trop haut.

Tür zu hoch eingestellt.

Puerta demasiado alto.

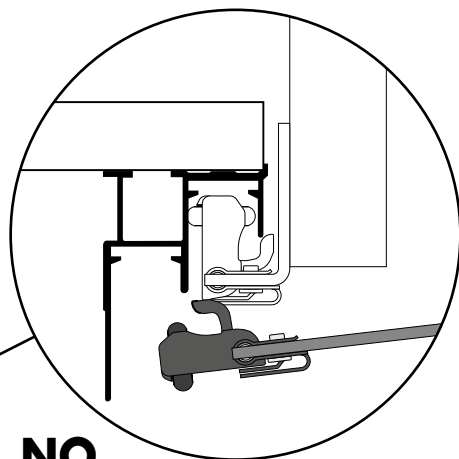
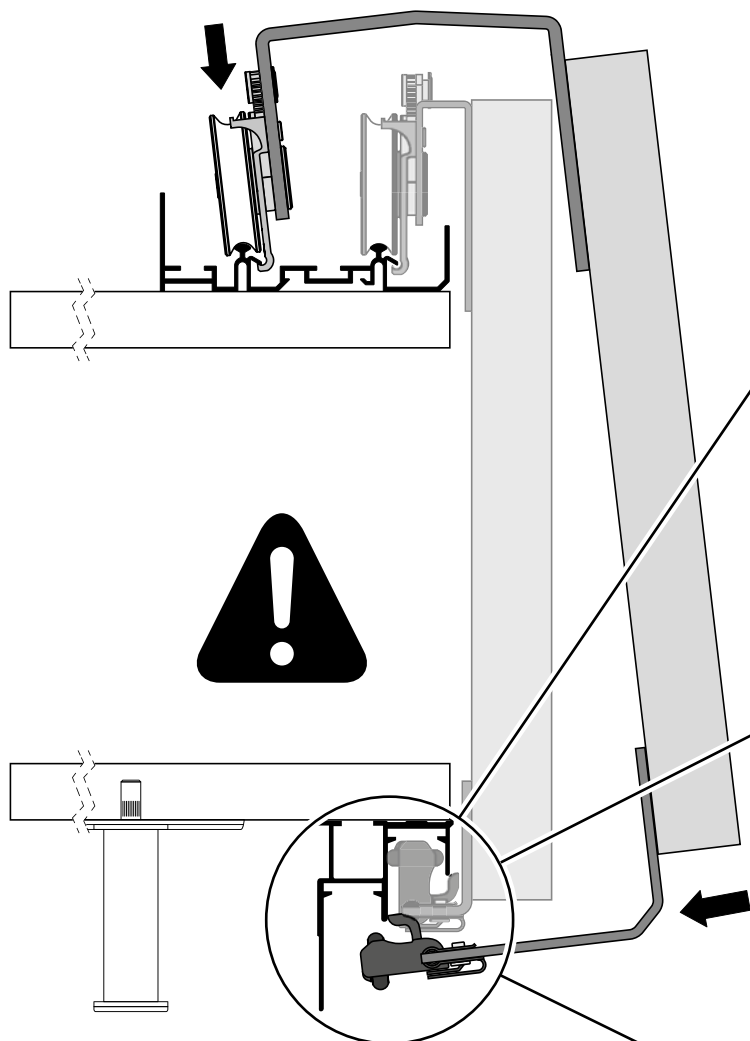
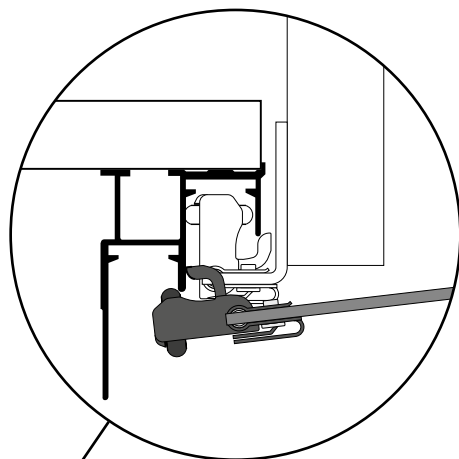

NO

Anta regolata troppo in basso.

Door adjusted too low.

Porte réglé trop bas.

Tür zu niedrig eingestellt.

Puerta demasiado bajo.

OK

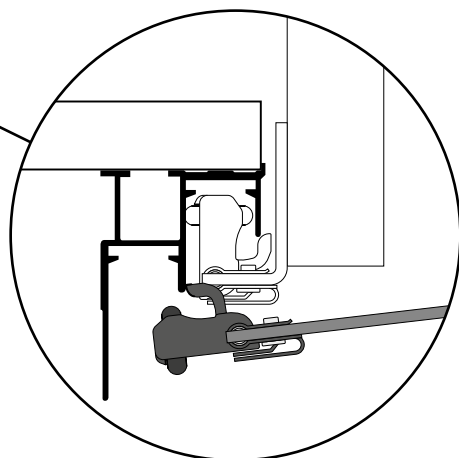

11

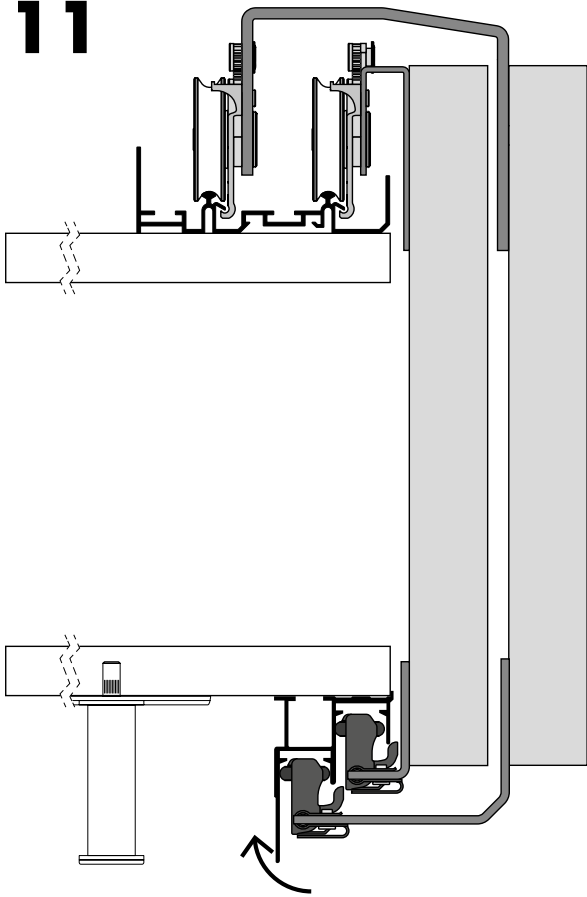

12

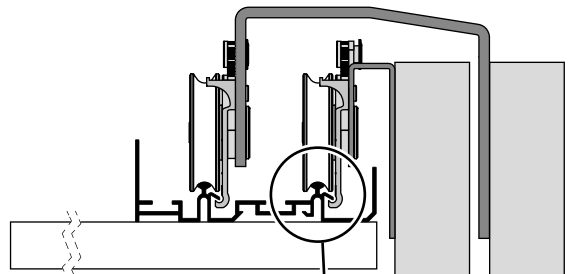
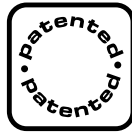

SISTEMA ANTISCARRUCOLAMENTO

Ruotare l'antiscarrucolamento prima di togliere l'anta.

ANTIDERAILING DEVICE
Rotate the antiderailing device before remove the door.

SYSTÈME ANTI-DÉRAILLEMENT
Tourner l'anti-déraillement avant d'enlever la porte.

ENTGLEISUNGSSCHUTZ-SYSTEM
Vor dem Entfernen der Tür das Entgleisungsschutzsystem drehen.

SISTEMA ANTIDESCARRILAMIENTO
Gire el antidescarrilamiento antes de sacar la puerta.

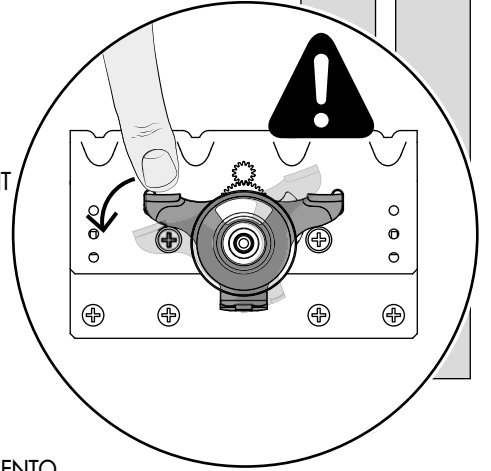

13

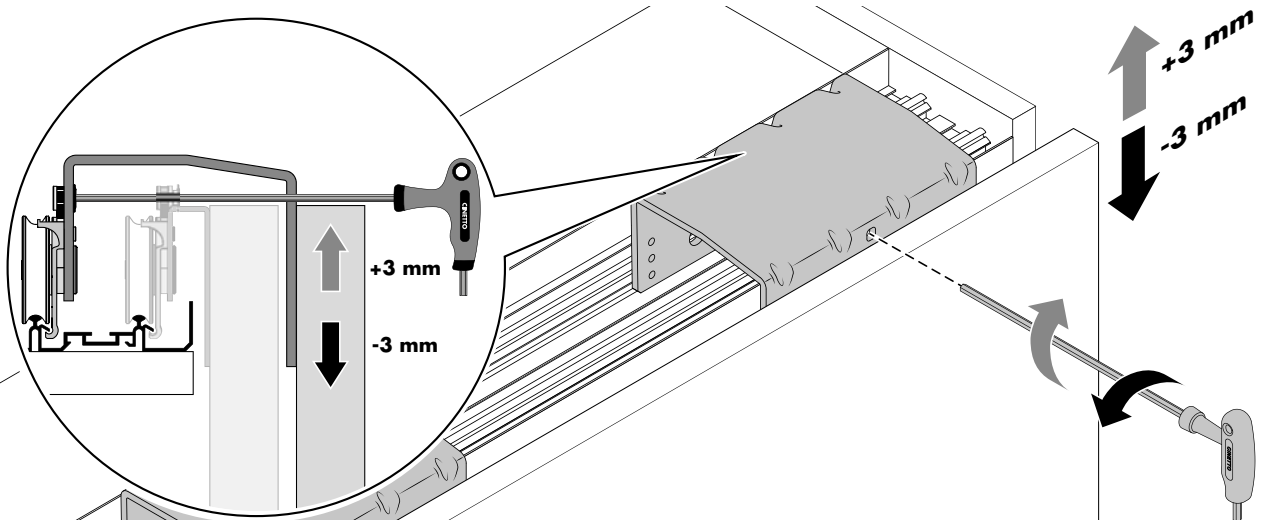

14

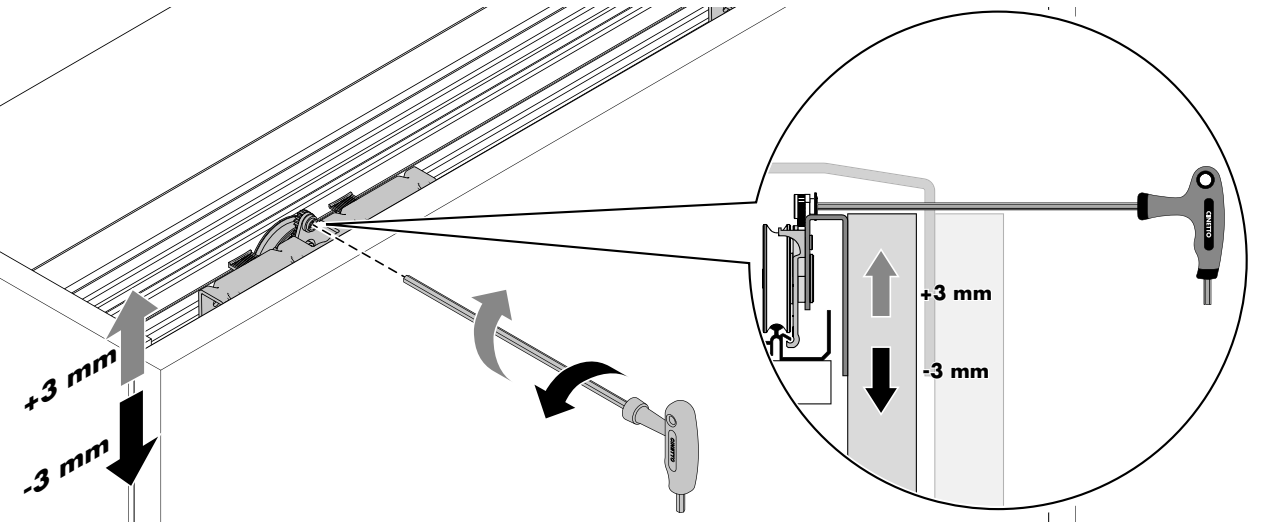
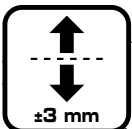

15

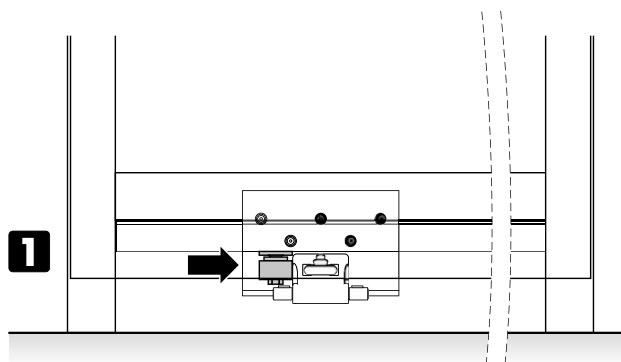

Chiudere l'anta e posizionare il fermo inferiore.

Close the door and positioning the lower lock.

Fermer la porte et placer l'arrêt inférieur.

Die Tür schließen und den unteren Anschlag hinlegen.

Cerrar la puerta y colocar el tope inferior.

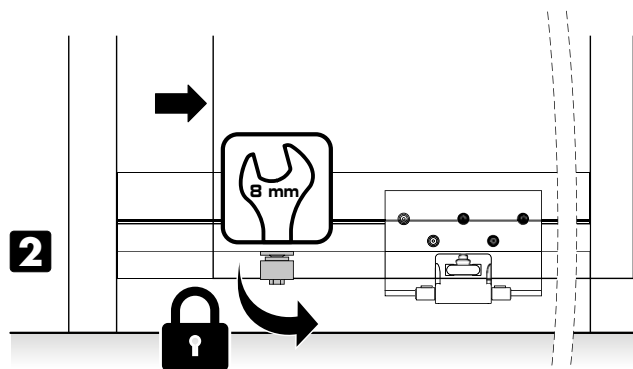

Aprire l'anta e fissare il fermo inferiore.

Open the door and fix the lower lock.

Ouvrier la porte et placer l'arrêt inférieur.

Die Tür aufmachen und den unteren Anschlag hinlegen.

Abrir la puerta y fijar el tope inferior.

16a

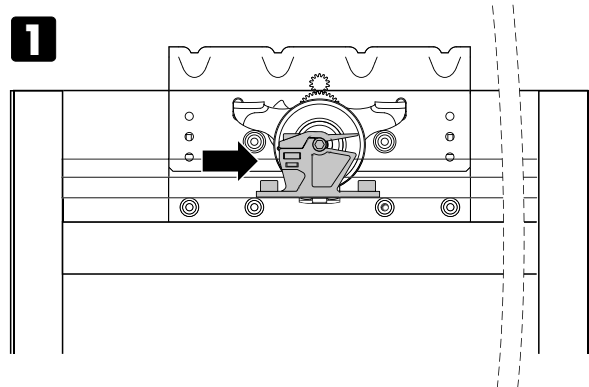

Chiudere l'anta e posizionare il fermo superiore.

Close the door and positioning the upper lock.

Fermer la porte et placer l'arrêt supérieur.

Die Tür schließen und den oberen Anschlag hinlegen.

Cerrar la puerta y colocar el tope superior.

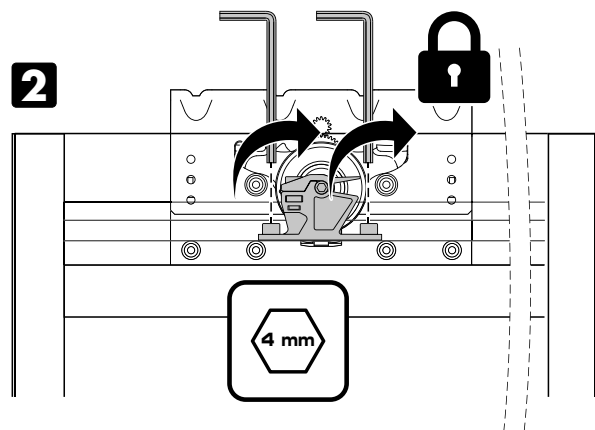

Fissare il fermo superiore.

Fix the upper lock.

Fixer l'arrêt supérieur.

Den oberen Anschlag befestigen.

Fijar el tope superior.

16b

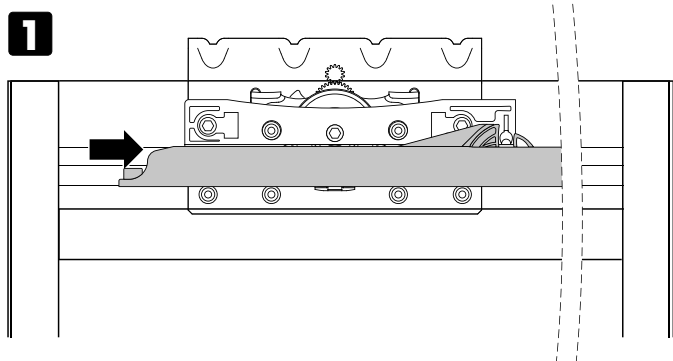

Chiudere l'anta e posizionare l'ammortizzatore.

Close the door and positioning the soft-closing device.

Fermer la porte et placer l'amortisseur.

Die Tür schließen und den Dämpfer legen.

Cerrar la puerta e colocar el amortiguador.

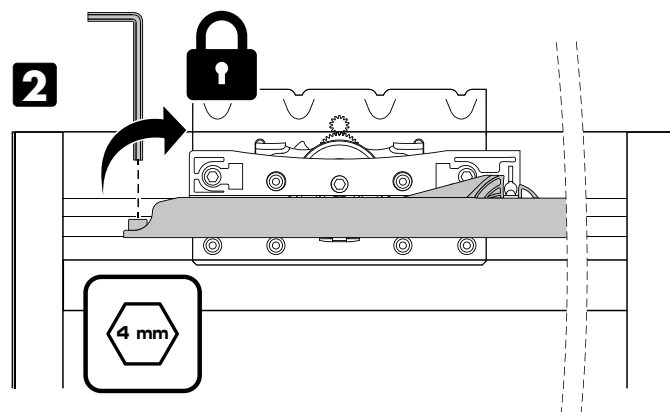

Fissare l'ammortizzatore.

Fix the soft-closing device.

Fixer l'amortisseur.

Den Dämpfer befestigen.

Fijar el amortiguador.

17

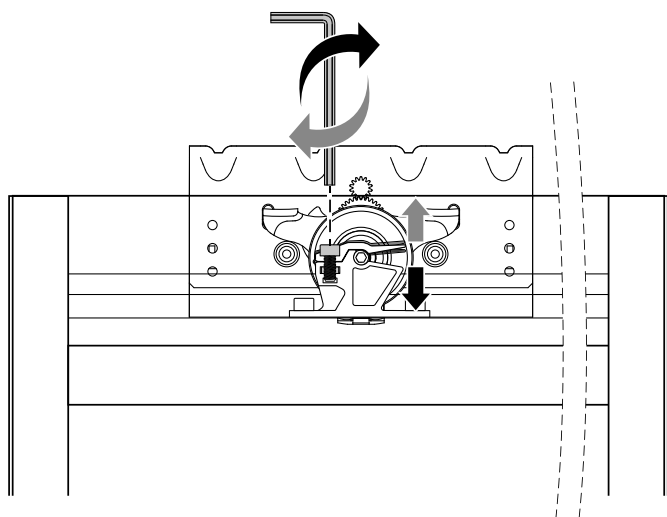

Regolare la forza di aggancio dei fermi superiori.

Adjust the force of clamping of the upper locks.

Régler la force d'accrochage des fermetures supérieures.

Die Einhakkraft der oberen Anschläge einstellen.

Regule la fuerza de enganche de los retenes superiores.

18

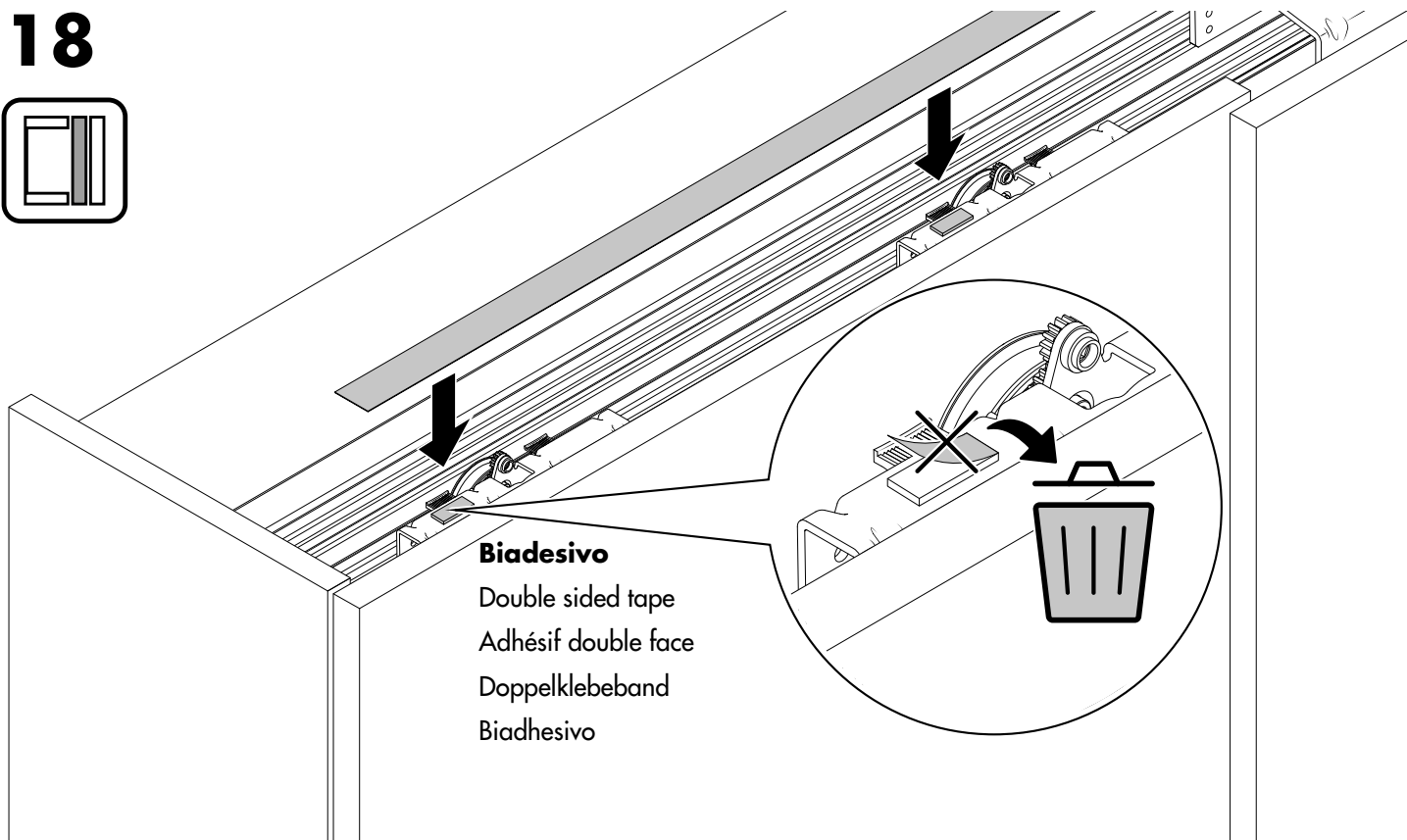
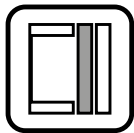

Biadesivo

Double sided tape
Adhésif double face
Doppelklebeband
Biadhesivo

19

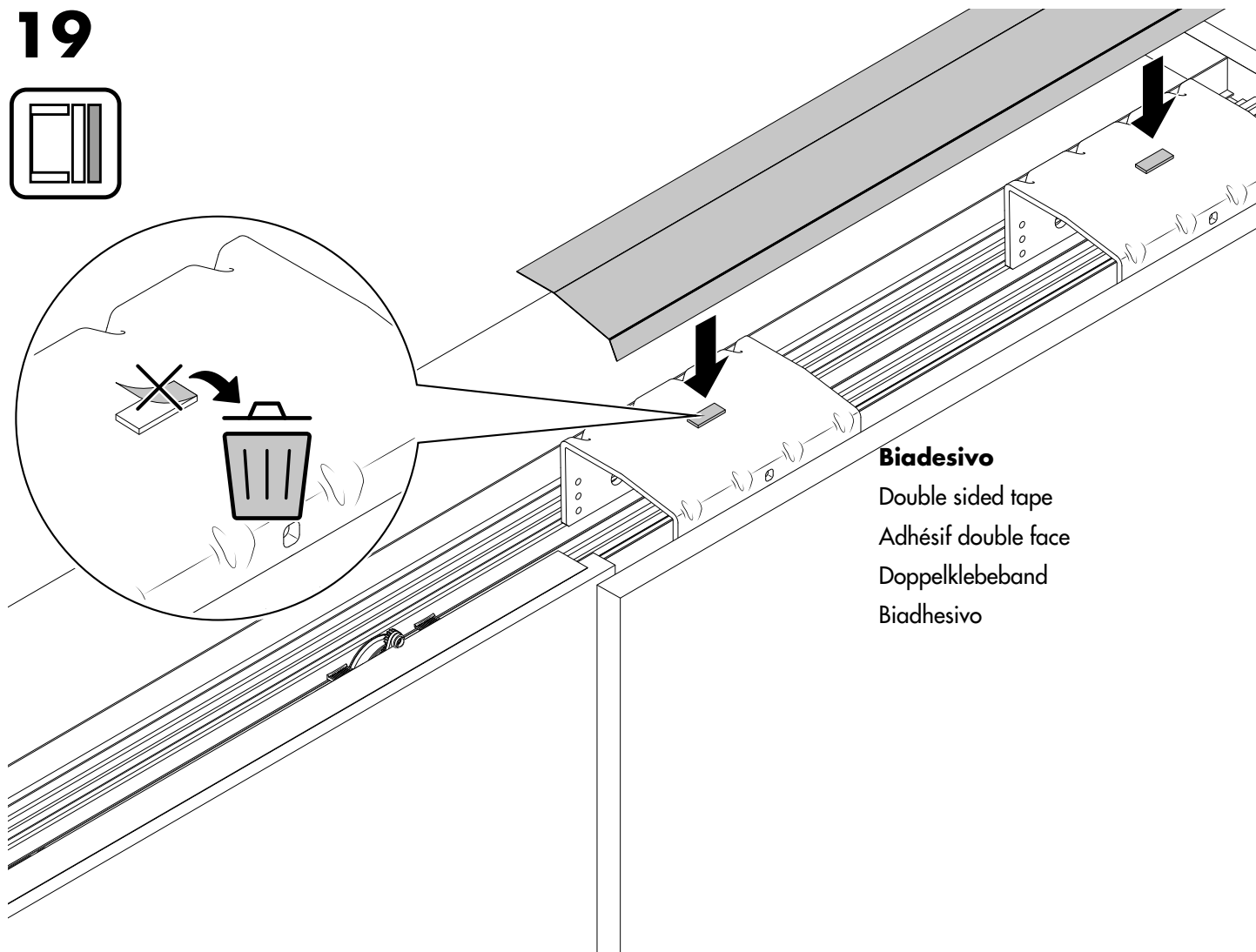
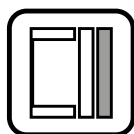

Biadesivo

Double sided tape
Adhésif double face
Doppelklebeband
Biadhesivo

Icone

Icons

Icônes

Icons

Iconos

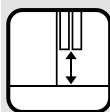

Spazio tra anta e pavimento

Space from the door and the floor
Espace entre la porte et le plancher
Raum zwischen Tür und Boden
El espacio entre la puerta y el piso

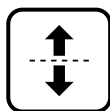

Regolazione verticale

Vertical adjustment
Ajustement vertical
Höhenverstellung
Regulación vertical

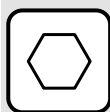

Chiave esagonale

Allen-key
Clé hexagonale
Sechskantenschlüssel
Llave hexagonal



Sistema brevettato

Patented system
Système breveté
Patentiertes System
Sistema patentado



Anta interna sinistra

Left internal door
Porte intérieure gauche
Interne linke Tür
Puerta interna izquierda



Senza sistema di ammortizzazione

Without soft-closing device
Sans système d'amortissement
Ohne Dämpfungssystem
Sin sistema de amortización



Sistema di ammortizzazione EASY-LINE

Soft-closing EASY-LINE device
Système d'amortissement EASY-LINE
EASY-LINE Dämpfungssystem
Sistema de amortización EASY-LINE



Sistema di ammortizzazione monodirezionale

One-way soft-closing device
Système d'amortissement monodirectionnel
Unidirektionales Dämpfungssystem
Sistema de amortización monodireccional



Sistema di ammortizzazione bidirezionale

Two-way soft-closing device
Système d'amortissement bidirectionnel
Bidirektionales Dämpfungssystem
Sistema de amortización bidireccional

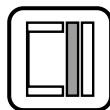

Anta interna

Internal door
Porte intérieure
Interne Tür
Puerta interna

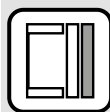

Anta esterna

External door
Porte extérieure
Externe Tür
Puerta externa



Cinetto F.lli S.r.l.

Via Rossi, 5/A
35030 Rubano (PD) Italy
Tel. +39 049 8977211
Fax +39 049 635822
www.cinetto.it
info@cinetto.it

