

PS40.1

MADE IN ITALY

Sistema complanare

Coplanar system

Système complanaire

Frontbündiges Schiebetürsystem für große Schränke

Sistema coplanario para grandes armarios

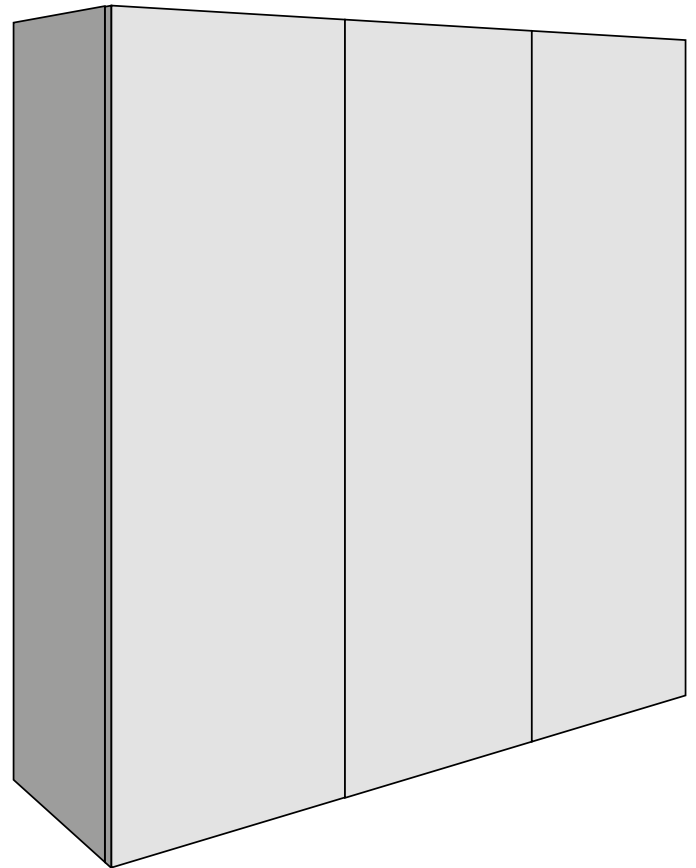
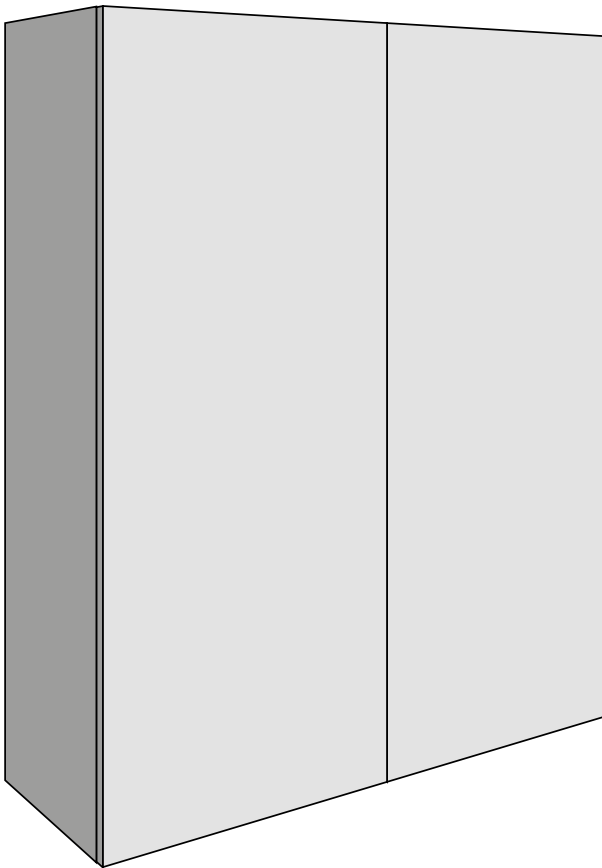

Istruzioni di montaggio

Assembly instructions

Instructions de montage

Montageanleitungen

Instrucciones des ensamblaje



Italiano

Tutte le misure espresse in questo opuscolo sono in millimetri.

ATTENZIONE

Non utilizzare spray ed oli anti frizione o sblocca filetti sui cuscinetti o sulle ruote con O-ring dei pattini scorrevoli. Questo provoca lo scioglimento dei grassi dei cuscinetti rendendoli rumorosi oppure la rottura dell'O-ring.

ABBREVIAZIONI

W	larghezza
WA	larghezza anta
L	lunghezza
LB	lunghezza binario
D	profondità
H	altezza
I	interasse
T	spessore
S	sormonto

Le illustrazioni e le descrizioni di questo opuscolo si intendono fornite a titolo indicativo. L'azienda si riserva pertanto di apportare, in qualsiasi momento e senza preavviso, quelle modifiche che ritenesse utili per qualsiasi esigenza di carattere costruttivo e commerciale.

Deutsch

Alle Maße in diesem Katalog sind in Millimetern.

ACHTUNG

Kein Spray, Schmiermittel oder Lösen-mittel auf die Kugellager und Rollen mit O-Ring der Laufwagen verwenden. Das kann die Kugellager und die Rollen geräuschvoller machen und kann den O-Ring Abriss verursachen.

ABKÜRZUNGS

W	Breite
WA	Türbreite
L	Länge
LB	Länge Schienen
D	Tiefe
H	Höhe
I	Abstand zwischen den Zentren
T	Dicke
S	Überlappung

Die Bilder und Beschreibungen dieses Prospektes sind nur zur Information gegeben. Die Firma kann, in jedem Moment, Änderungen und Verbesserungen ohne Vorankündigung vornehmen.

English

All dimensions in this leaflet are stated in millimeters.

WARNING

Do not use any anti-friction oil or grease or thread-release spray on ball bearing or on wheels with O-ring, it can cause the melting of the inside ball bearing grease, making them noisy or causing the break of the O-ring of the wheels.

ABBREVIATIONS

W	width
WA	door width
L	length
LB	rail length
D	depth
H	height
I	distance between centres
T	thickness
S	overlapping

The pictures and descriptions this leaflet contains are supplied for information purposes. The company reserves the right to introduce those modifications it deems opportune for any construction or commercial need at any time and without advance notice.

Español

Todas las dimensiones en este folleto se expresan en milímetros.

ADVERTENCIA

No utilices spray y aceites anti-fricción sobre los cojinetes de bolas y sobre las ruedas con O-ring de los patines. Esto puede provocar mayor rumorosidad de los cojines o la rotura de los O-ring.

ABREVIACIONES

W	anchura
WA	anchura de la puerta
L	longitud
LB	longitud de la guía
D	profundidad
H	altura
I	distancia entre centros
T	espesor
S	superposición

Las imagines y las descripciones de este folleto solo se fechas a título informativo. La empresa puede aportar, en cualquier momento y sin preaviso, las modificaciones que cree necesarias por exigencias técnicas y comerciales.

Français

Toutes les mesures indiquées dans cette brochure sont en millimètres.

AVERTISSEMENT

Ne pas utiliser de spray ni d'huile anti frottement ou pour débloquer les filets sur les coussinets ou sur les roulettes avec bague torique des patins coulissants. Ce qui ferait fondre la graisse des roulements en les rendant bruyants ou provoquerait la rupture de la bague torique.

ABRÉVIATIONS

W	largeur
WA	largeur de la porte
L	longueur
LB	longueur de le rail
D	profondeur
H	hauteur
I	entraxe
T	épaisseur
S	chevauchement

Les images et les descriptions de cette notice ne sont fournies qu'à titre indicatif. Le fabricant se réserve donc le droit d'apporter toutes les modifications qu'il jugera utiles à des fins techniques et commerciales à n'importe quel moment et sans aucun préavis.

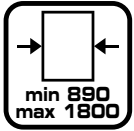
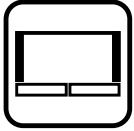
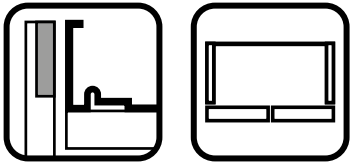

$LB = 2WA + X - 2S$
$WA = (LB - X + 2S) / 2$

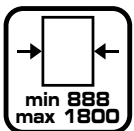
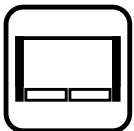
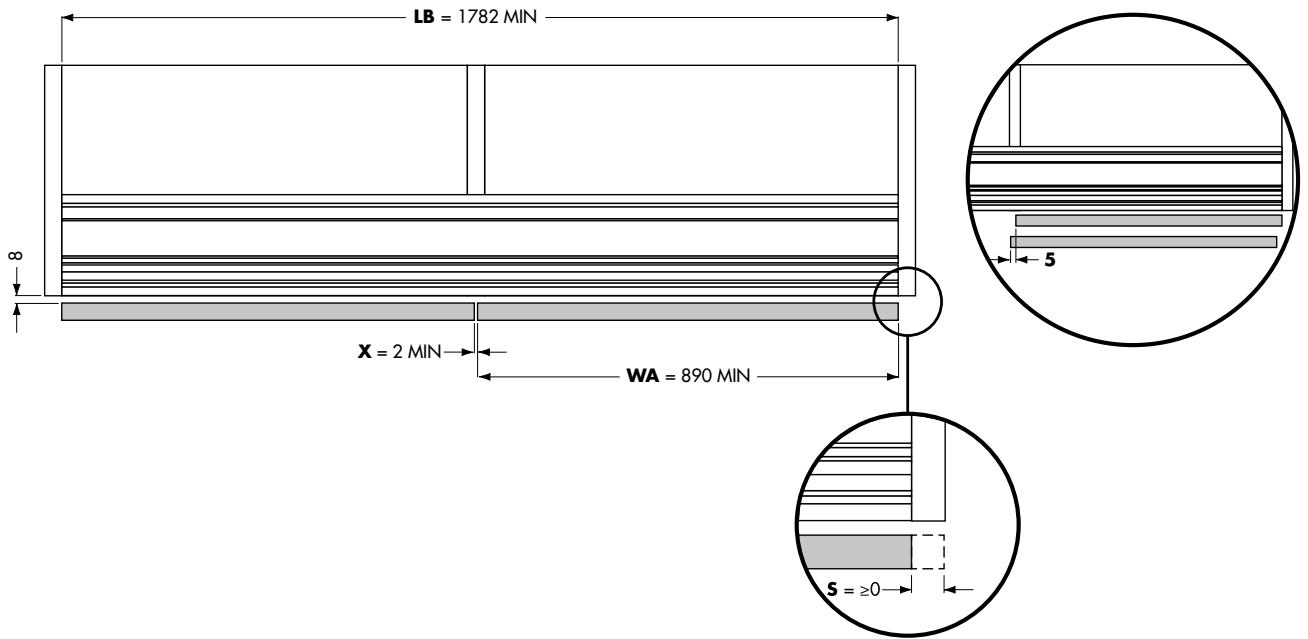

$LB = WA + 3X$
$WA = (LB - 3X) / 2$

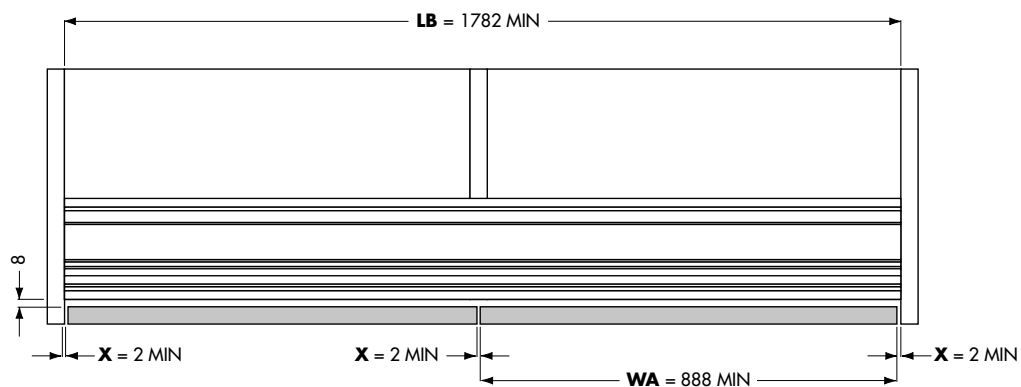

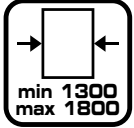
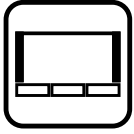
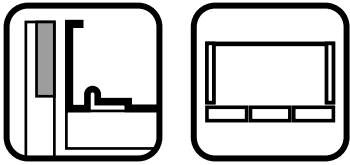

$LB = 3WA + 2X - 2S$
$WA = (LB - 2X + 2S) / 3$

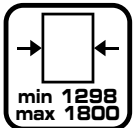
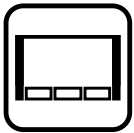
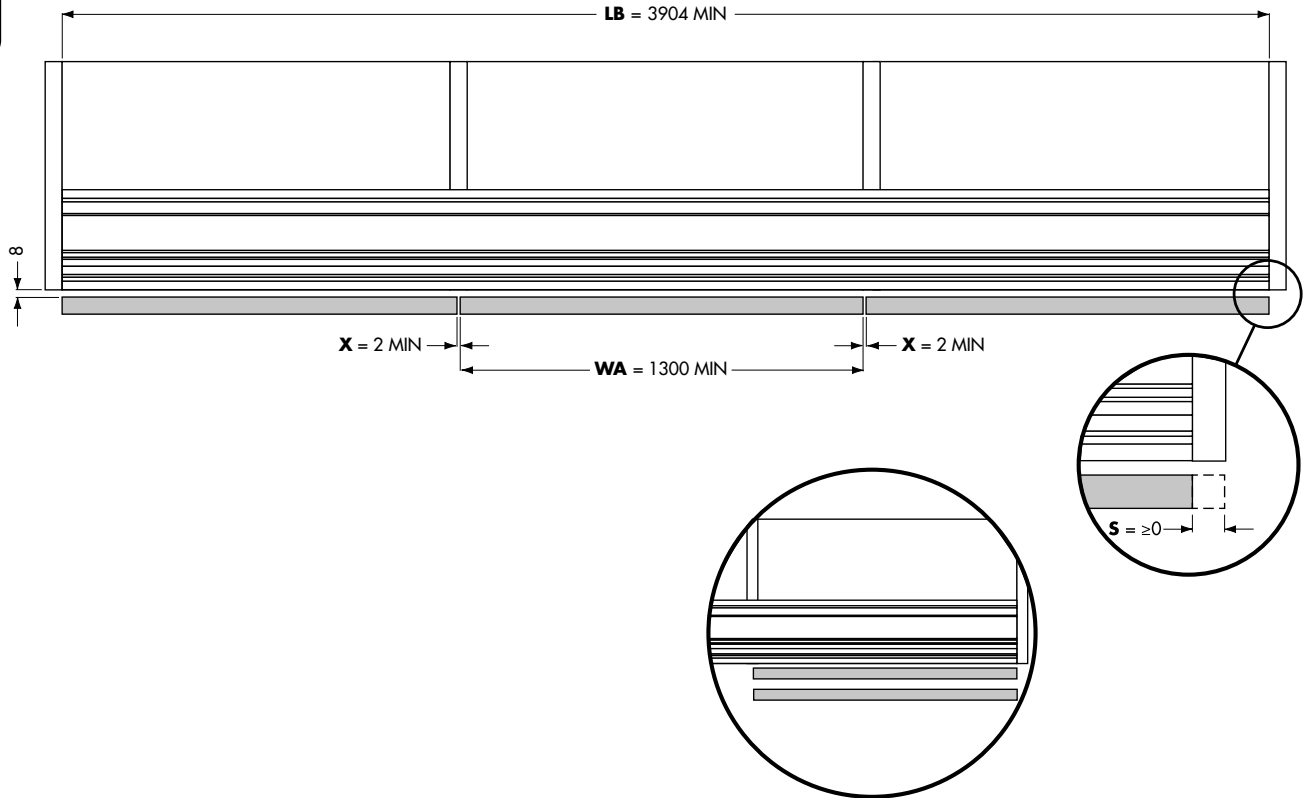

$LB = 3WA + 4X$
$WA = (LB - 4X) / 3$

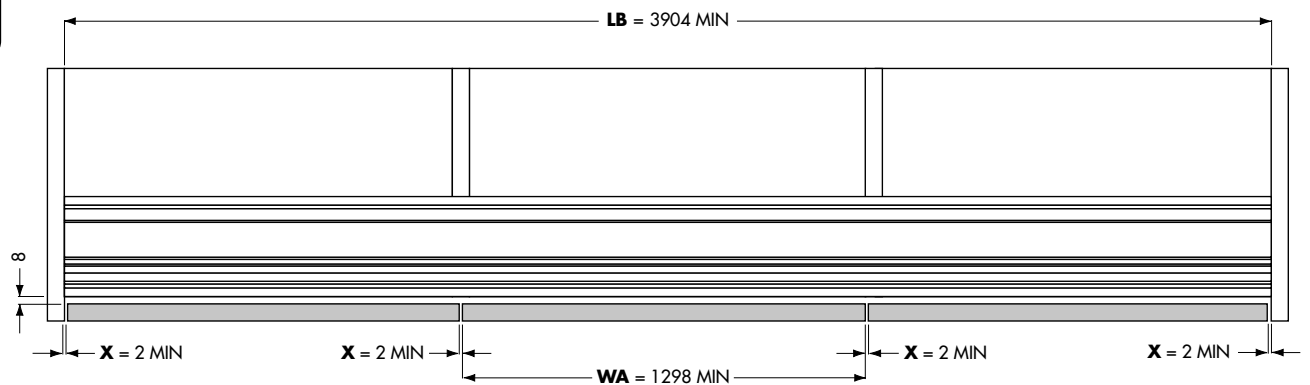

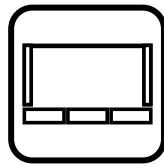
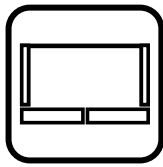
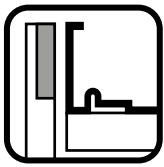

Lavorazioni richieste per le ante

Working requests for the doors

Usinage nécessaire pour les portes

Verarbeitungsanforderungen für die Türen

Laboreo necesario para las puertas



Il riferimento iniziale per effettuare le fresature è sempre il centro dell'anta, qualsiasi sia la sua larghezza.

The starting reference for making the milling / or drilling of the doors, is always the center of the door, whatever its width is.

La référence initiale pour effectuer le fraisage/ ou perçage de las portes, est toujours le centre de la porte, quelle que soit sa largeur.

Um das Fräsen / Bohrungen der Türe zu machen, der erste Bezugspunkt ist immer der Mittelpunkt der Tür, unabhängig von ihrer Breite.

La referencia inicial para moler ou hacer agujeros en las puertas, es siempre el centro de la puerta, cualquiera que sea su anchura.

1

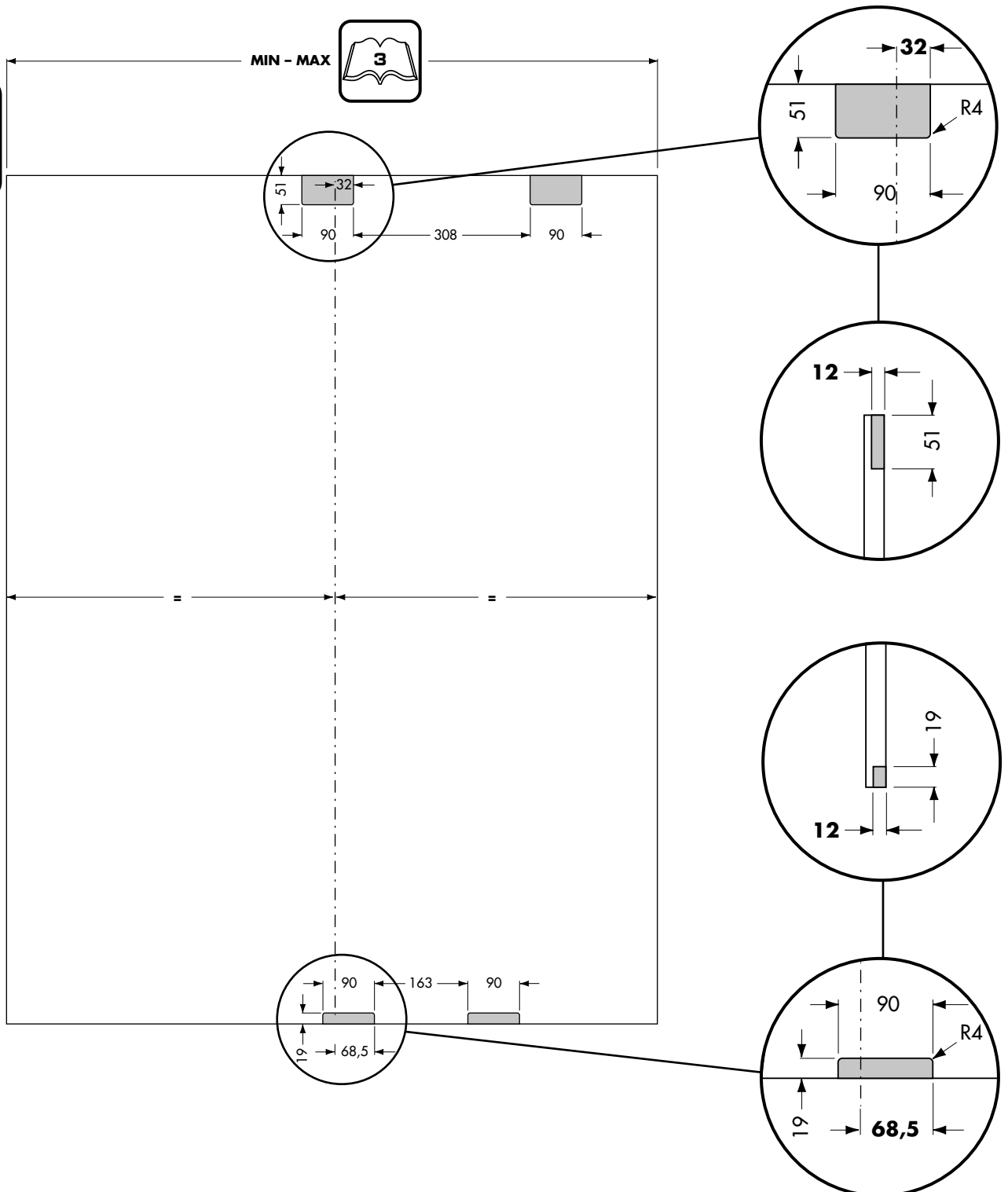
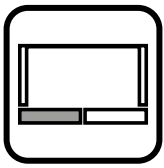

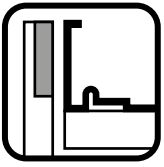

2

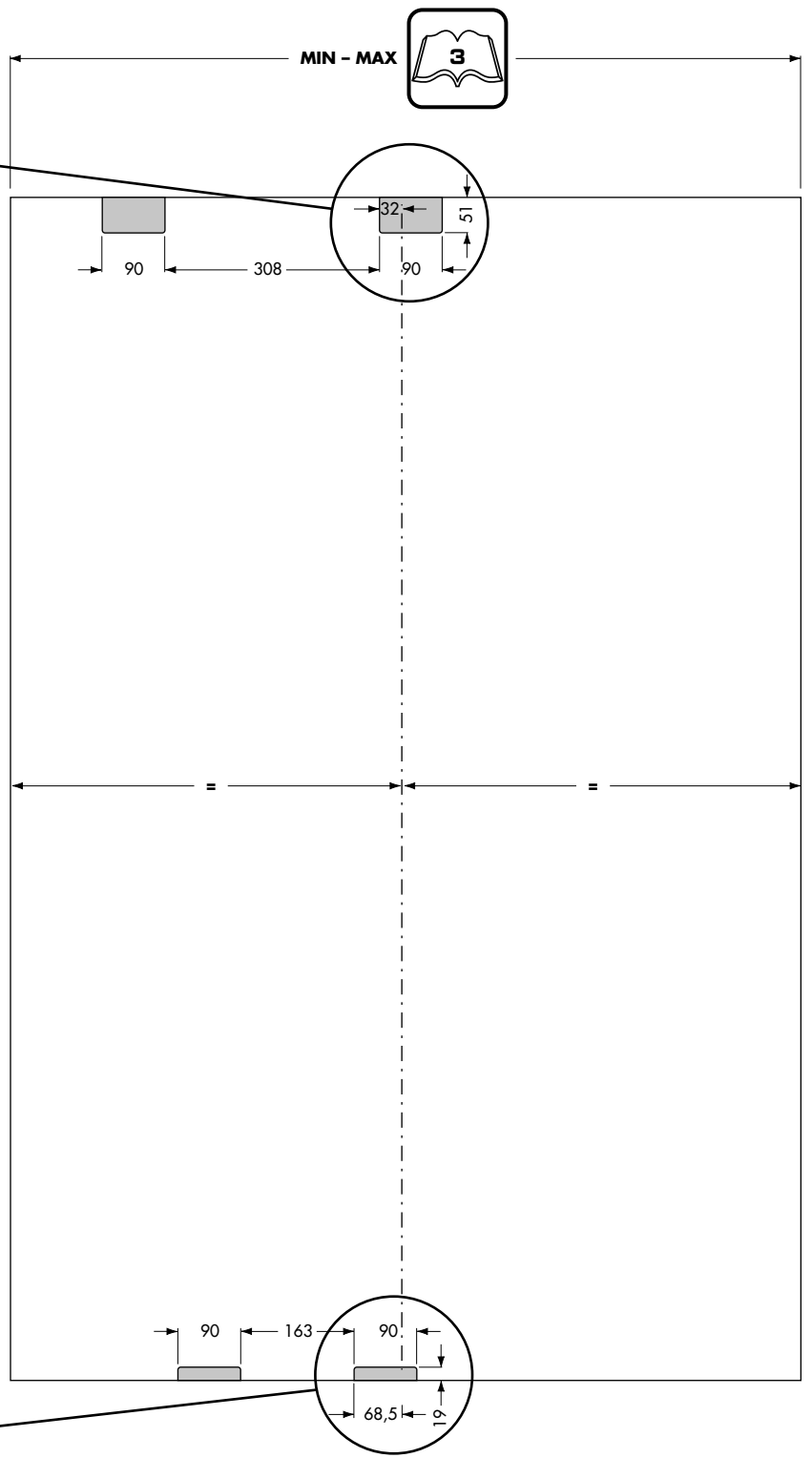
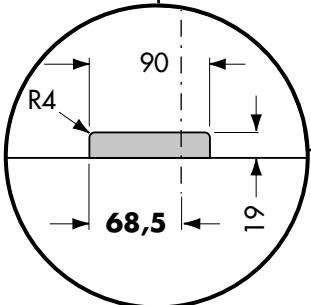
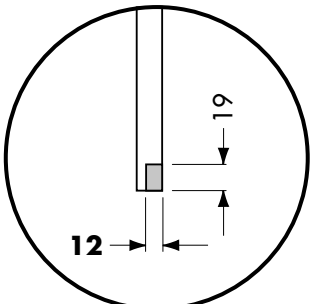
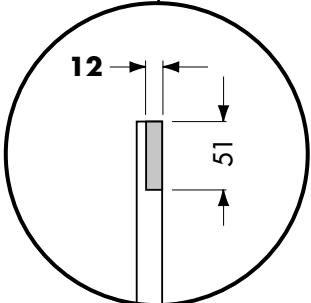
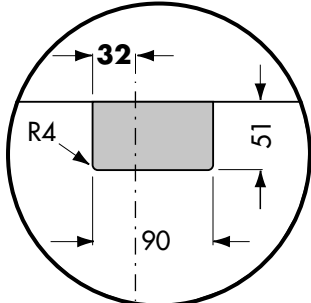
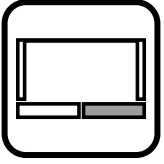



Il riferimento iniziale per effettuare le fresature è sempre il centro dell'anta, qualsiasi sia la sua larghezza.

The starting reference for making the milling / or drilling of the doors, is always the center of the door, whatever its width is.

La référence initiale pour effectuer le fraisage/ ou perçage de las portes, est toujours le centre de la porte, quelle que soit sa largeur.

Um das Fräsen / Bohrungen der Türe zu machen, der erste Bezugspunkt ist immer der Mittelpunkt der Tür, unabhängig von ihrer Breite.

La referencia inicial para moler o hacer agujeros en las puertas, es siempre el centro de la puerta, cualquiera que sea su anchura.

3

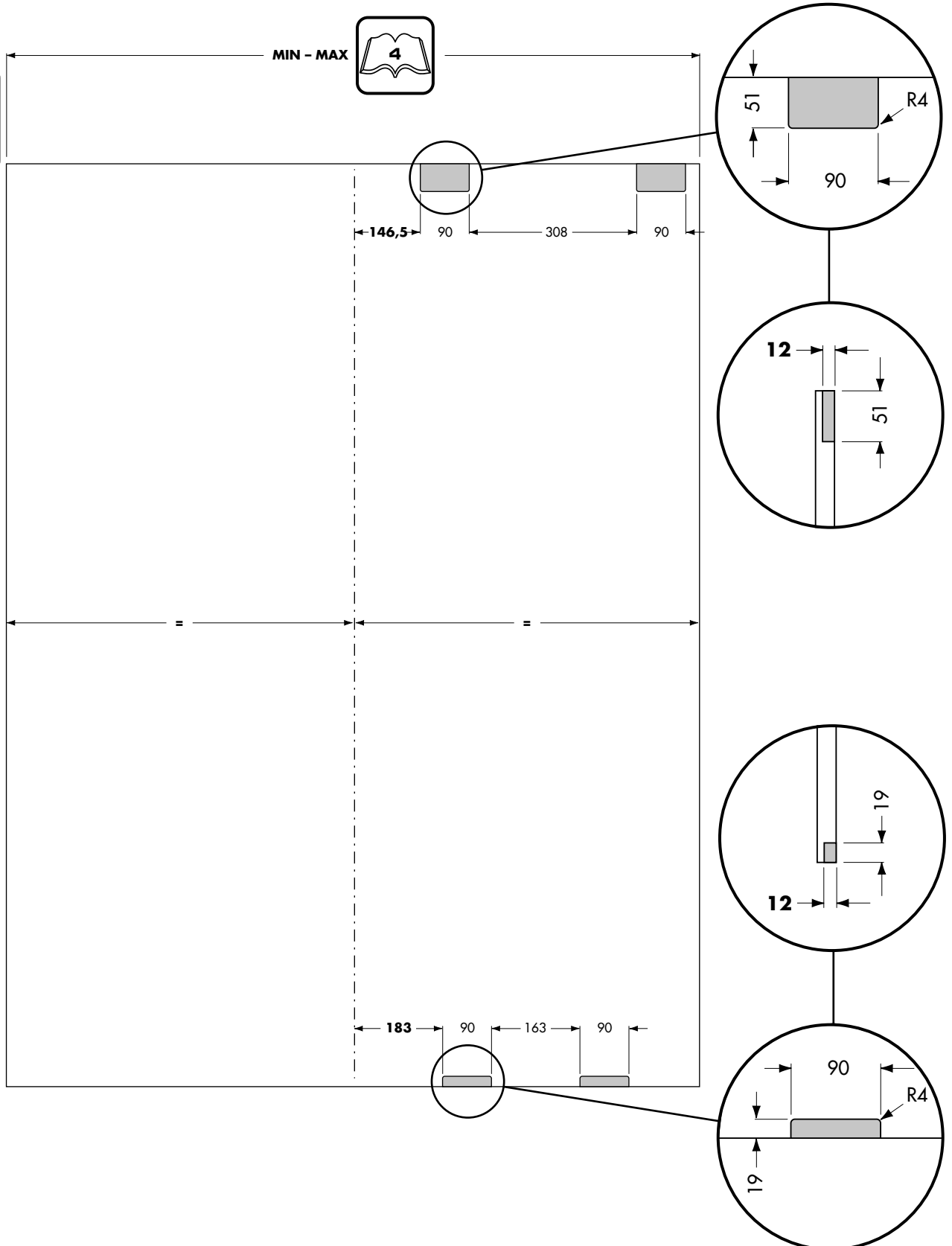
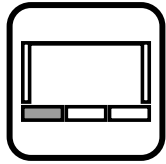

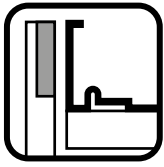

4

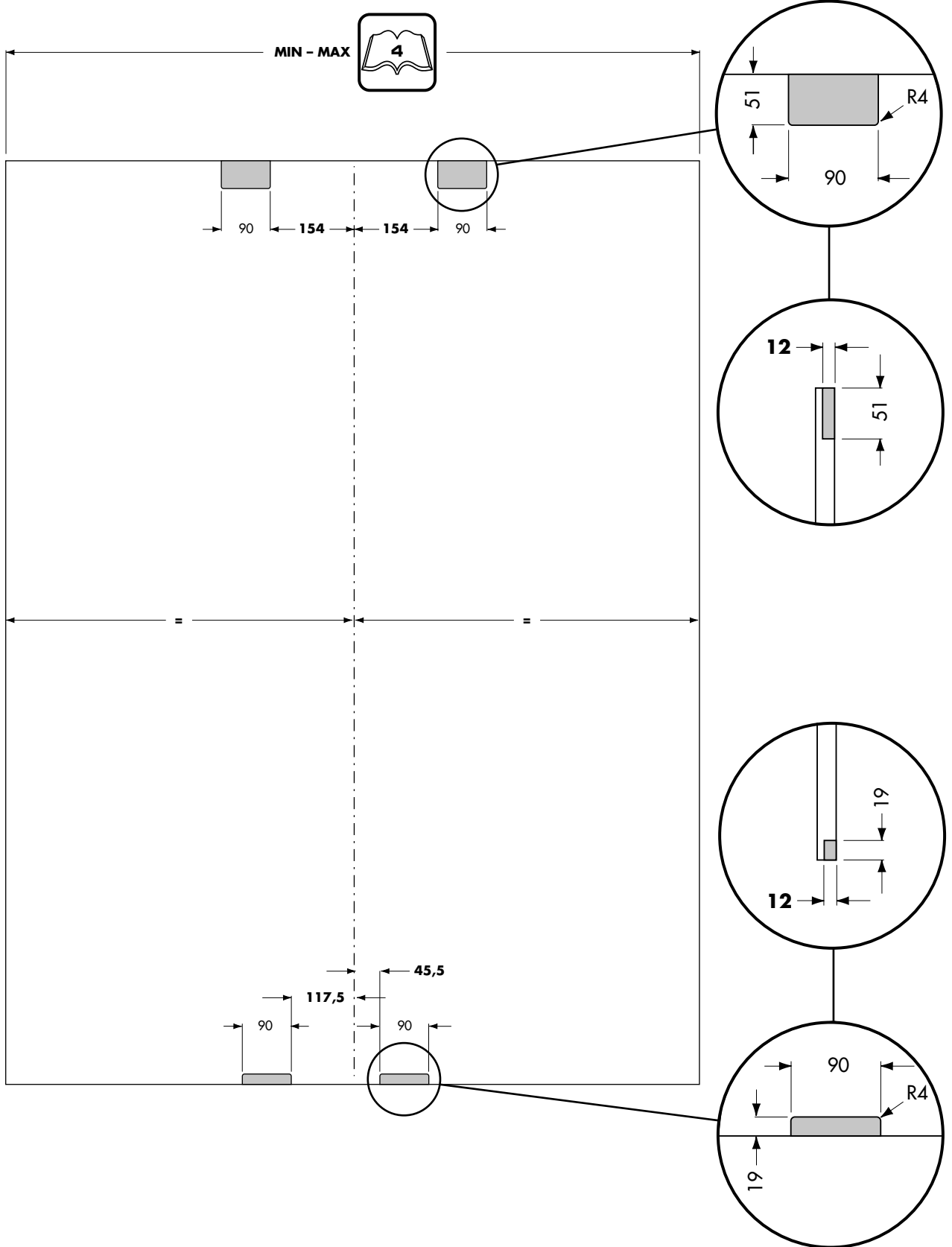
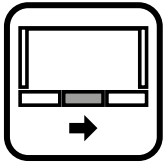



Il riferimento iniziale per effettuare le fresature è sempre il centro dell'anta, qualsiasi sia la sua larghezza.

The starting reference for making the milling / or drilling of the doors, is always the center of the door, whatever its width is.

La référence initiale pour effectuer le fraisage/ ou perçage de las portes, est toujours le centre de la porte, quelle que soit sa largeur.

Um das Fräsen / Bohrungen der Türe zu machen, der erste Bezugspunkt ist immer der Mittelpunkt der Tür, unabhängig von ihrer Breite.

La referencia inicial para molar ou hacer agujeros en las puertas, es siempre el centro de la puerta, cualquiera que sea su anchura.

5

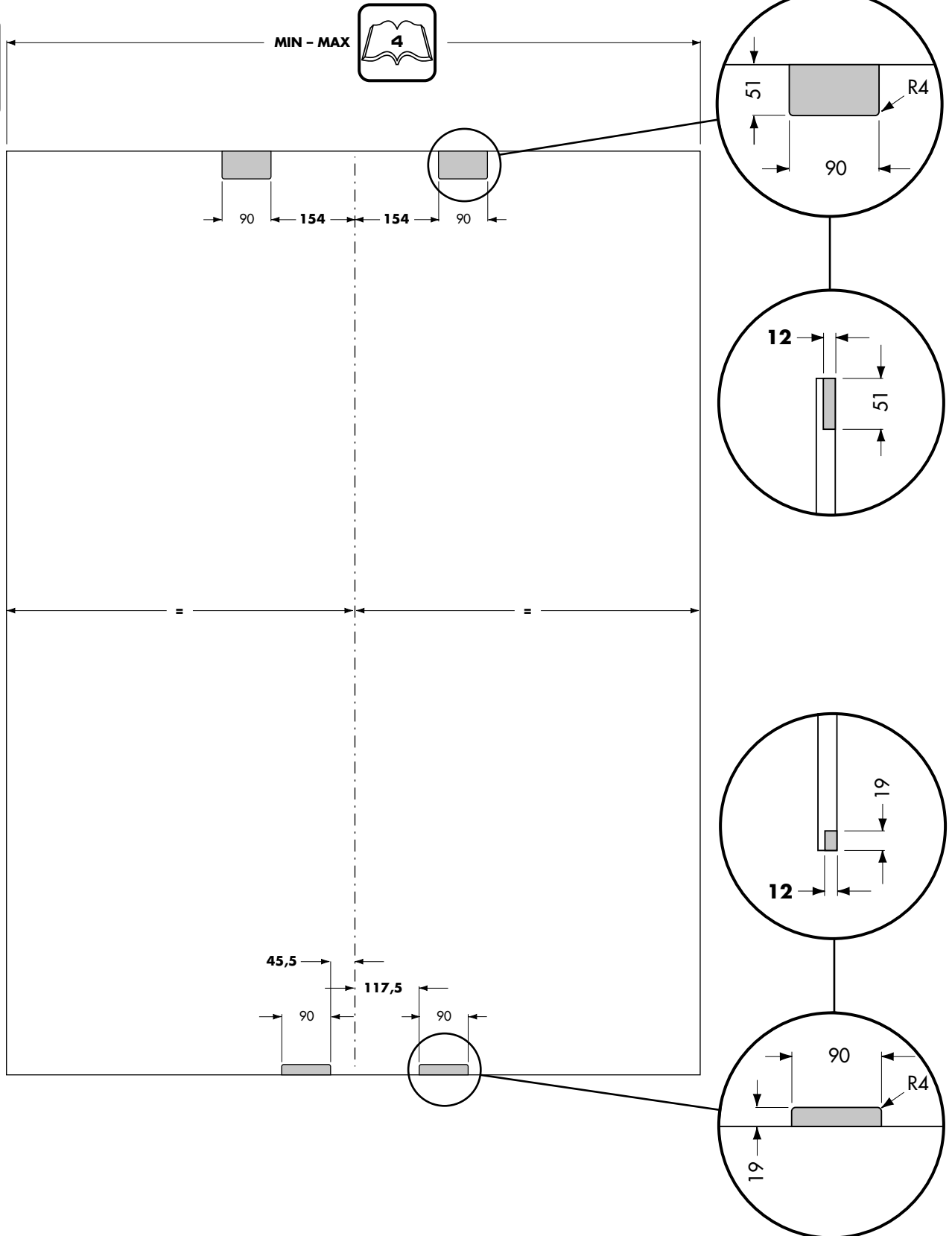
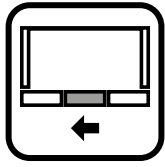

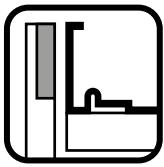

Il riferimento iniziale per effettuare le fresature è sempre il centro dell'anta, qualsiasi sia la sua larghezza.

The starting reference for making the milling / or drilling of the doors, is always the center of the door, whatever its width is.

La référence initiale pour effectuer le fraisage/ ou perçage de las portes, est toujours le centre de la porte, quelle que soit sa largeur.

Um das Fräsen / Bohrungen der Türe zu machen, der erste Bezugspunkt ist immer der Mittelpunkt der Tür, unabhängig von ihrer Breite.

La referencia inicial para moler ou hacer agujeros en las puertas, es siempre el centro de la puerta, cualquiera que sea su anchura.

6

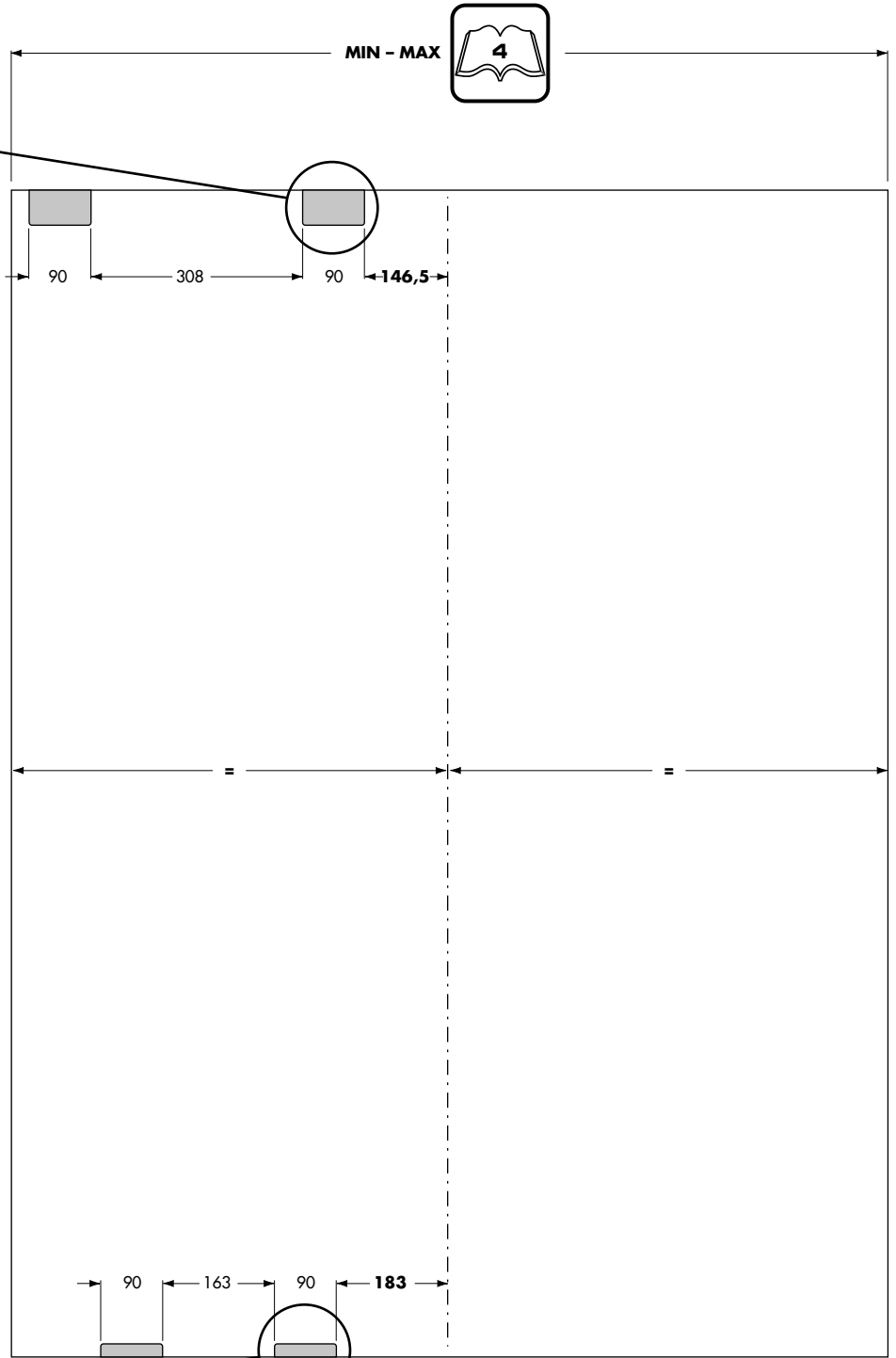
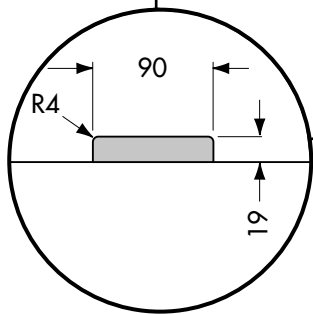
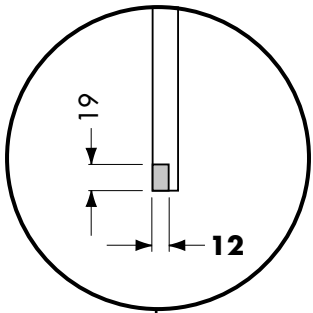
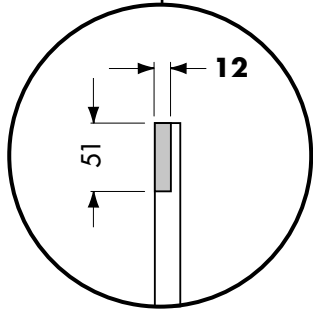
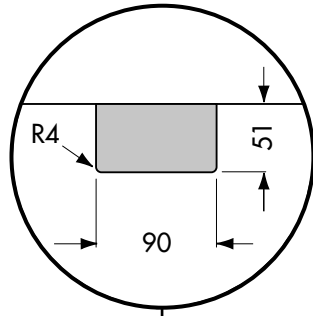
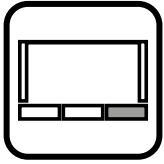

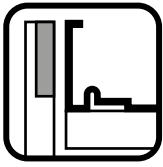

Configurazione armadio

Wardrobe configuration

Configuration de l'armoire

Schrankkonfiguration

Configuración del armario

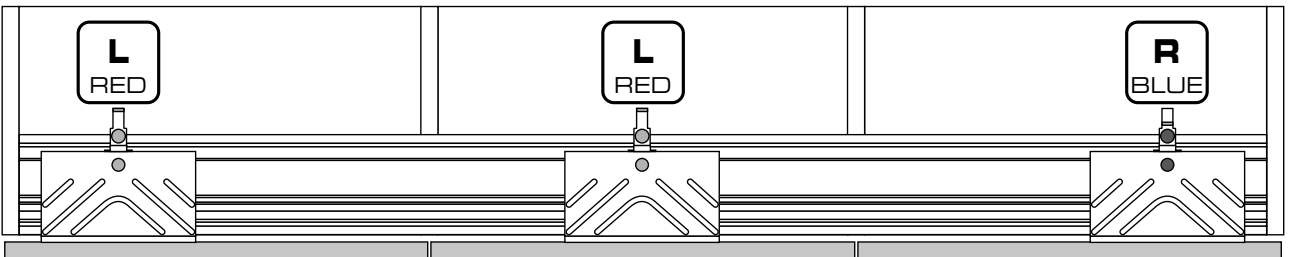
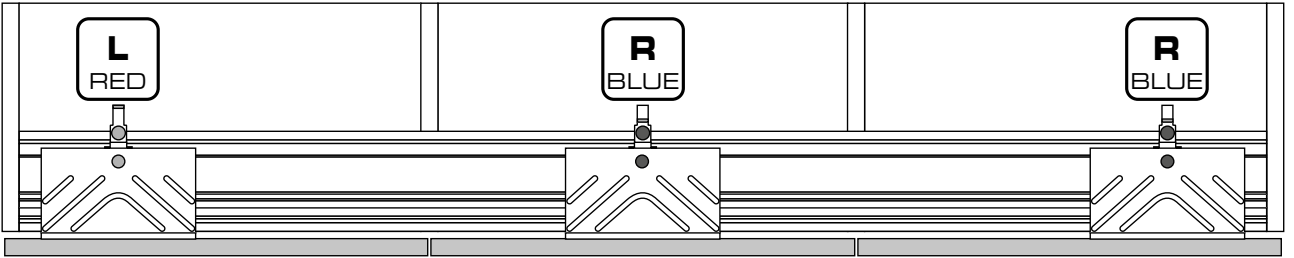
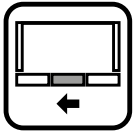
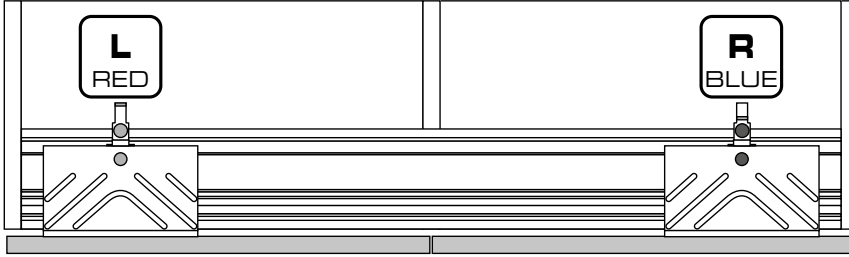
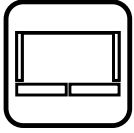

Istruzioni di montaggio

Assembly instructions

Instructions de montage

Montageanleitungen

Instrucciones de ensamblaje

1

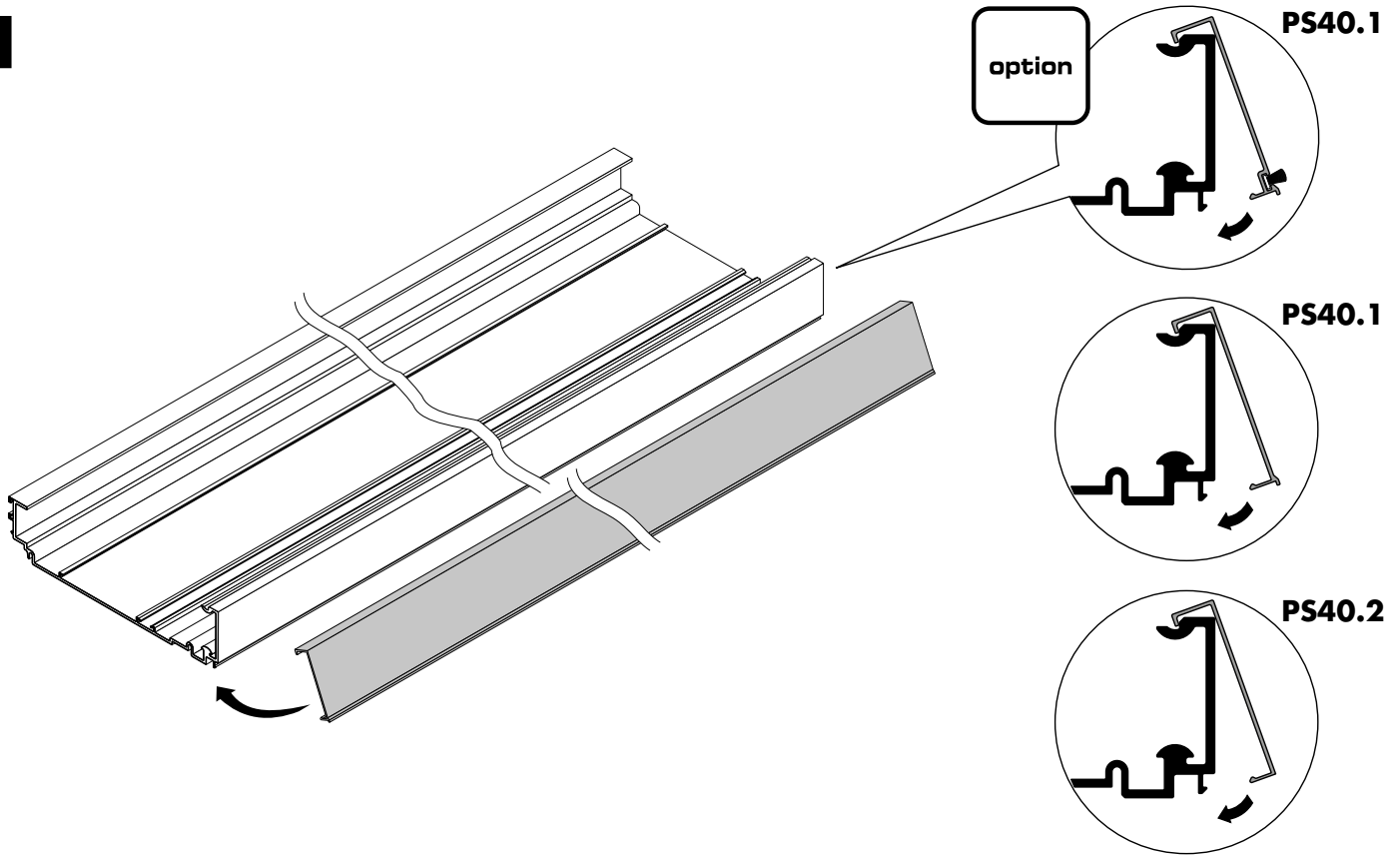

2

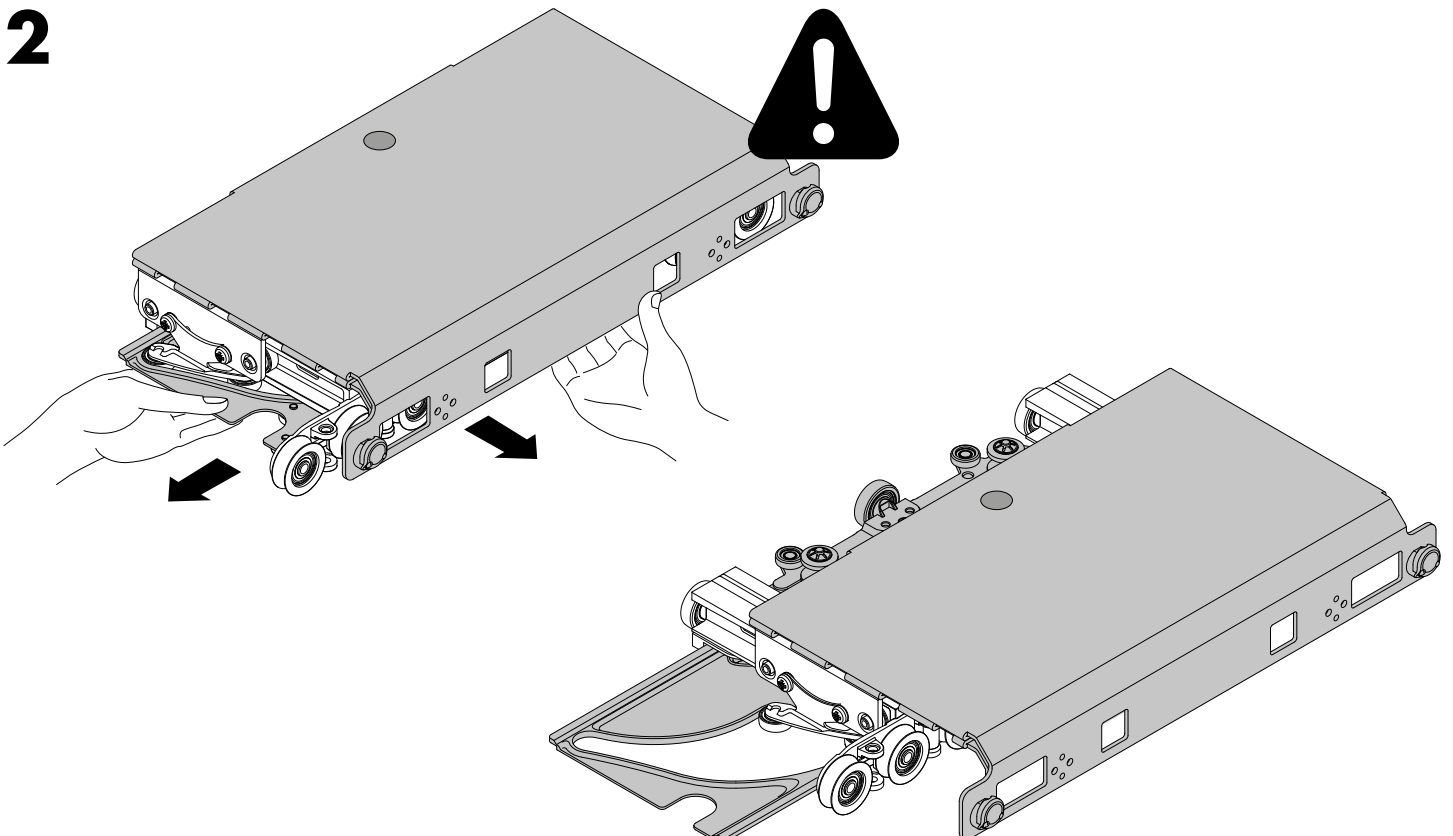

3

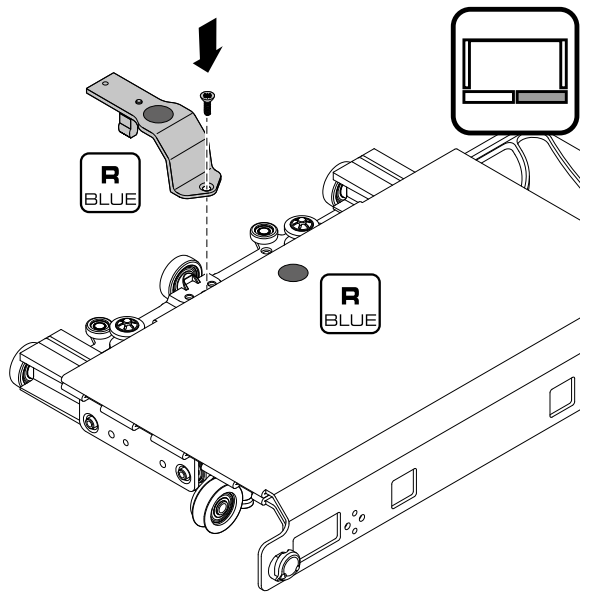
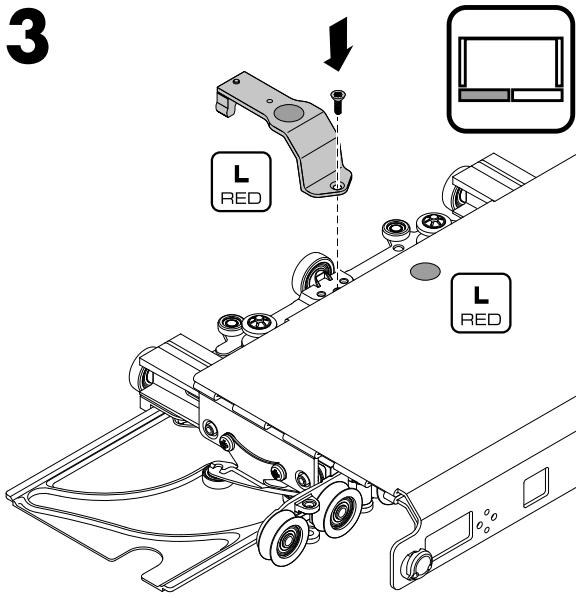

4

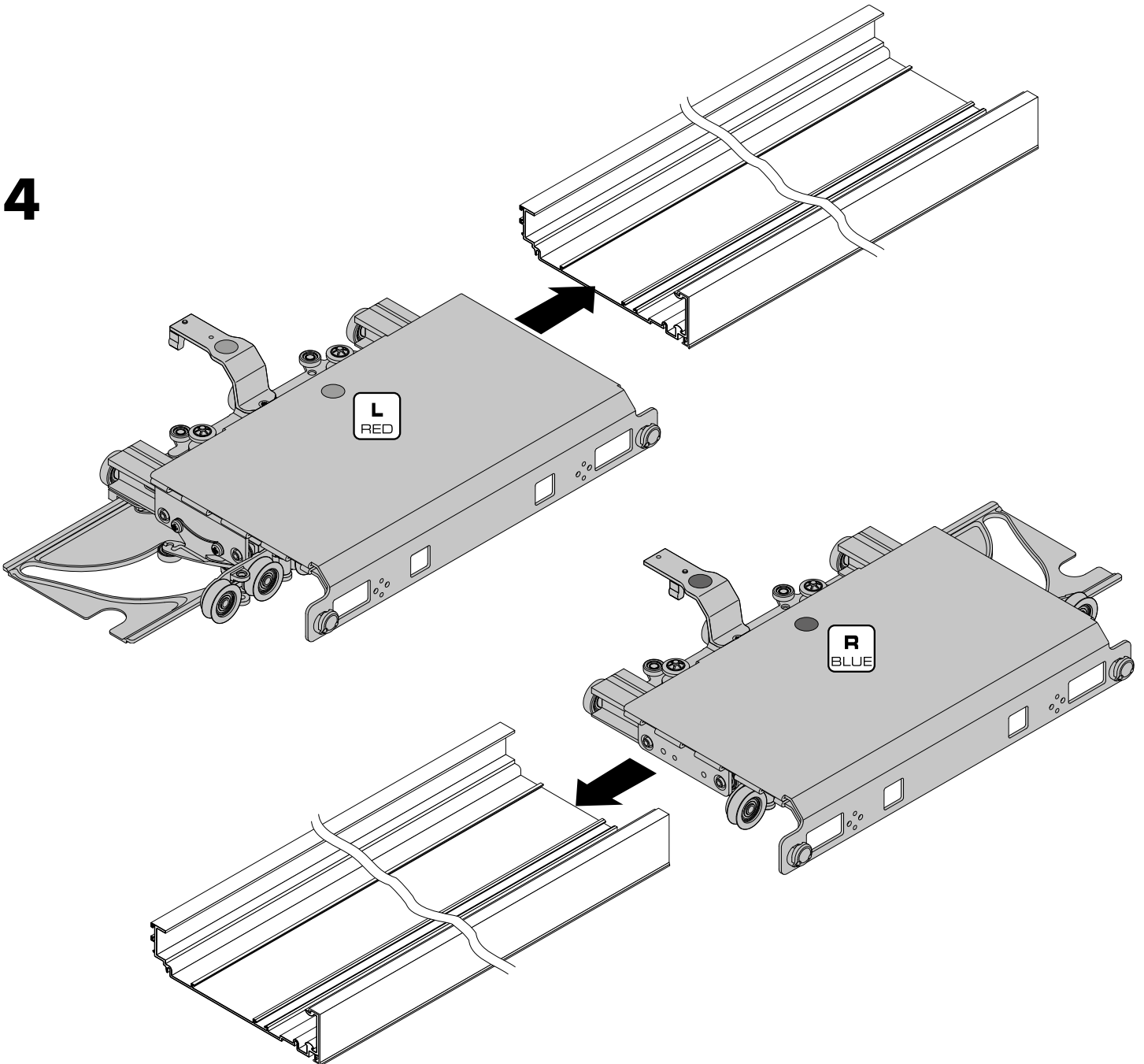

5

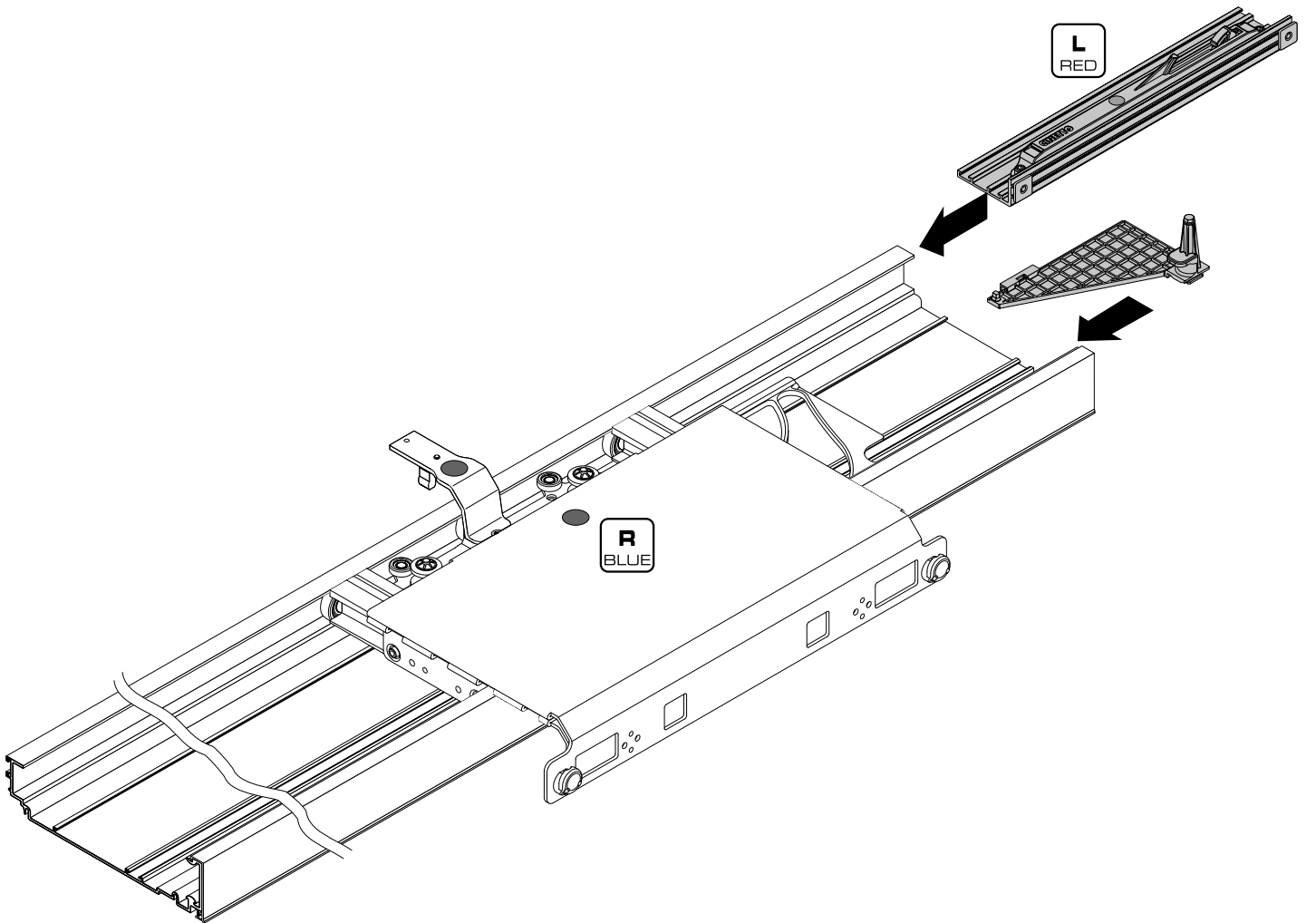
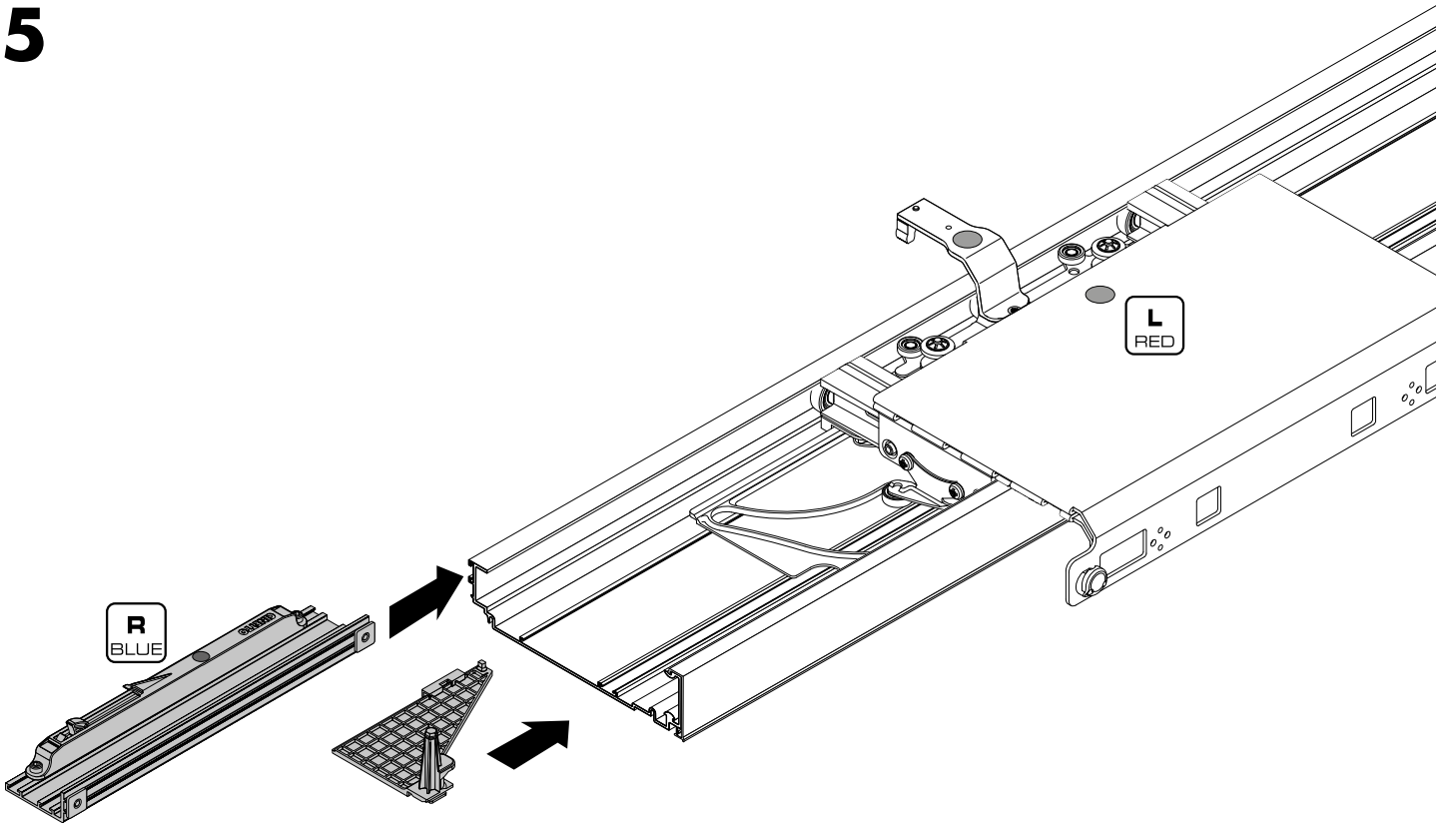



Posizionamento e fissaggio dei fermi superiori.

Positioning and fixing of the upper locks.

Positionnement et fixation des supports supérieurs.

Positionierung und Befestigung der oberen Aufschläge.

Posicionamiento y fijación de los topes superiores.

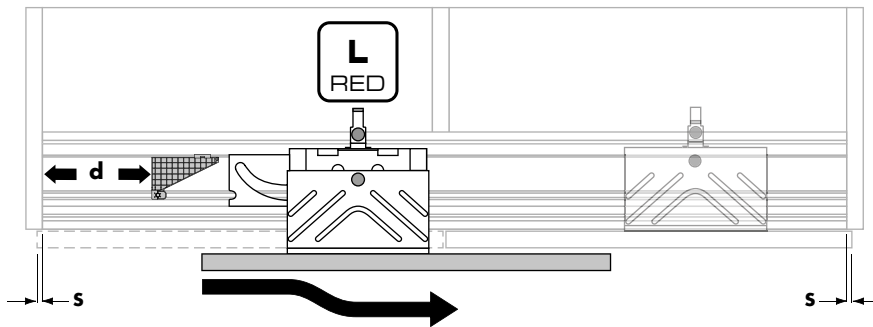
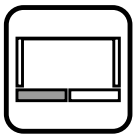
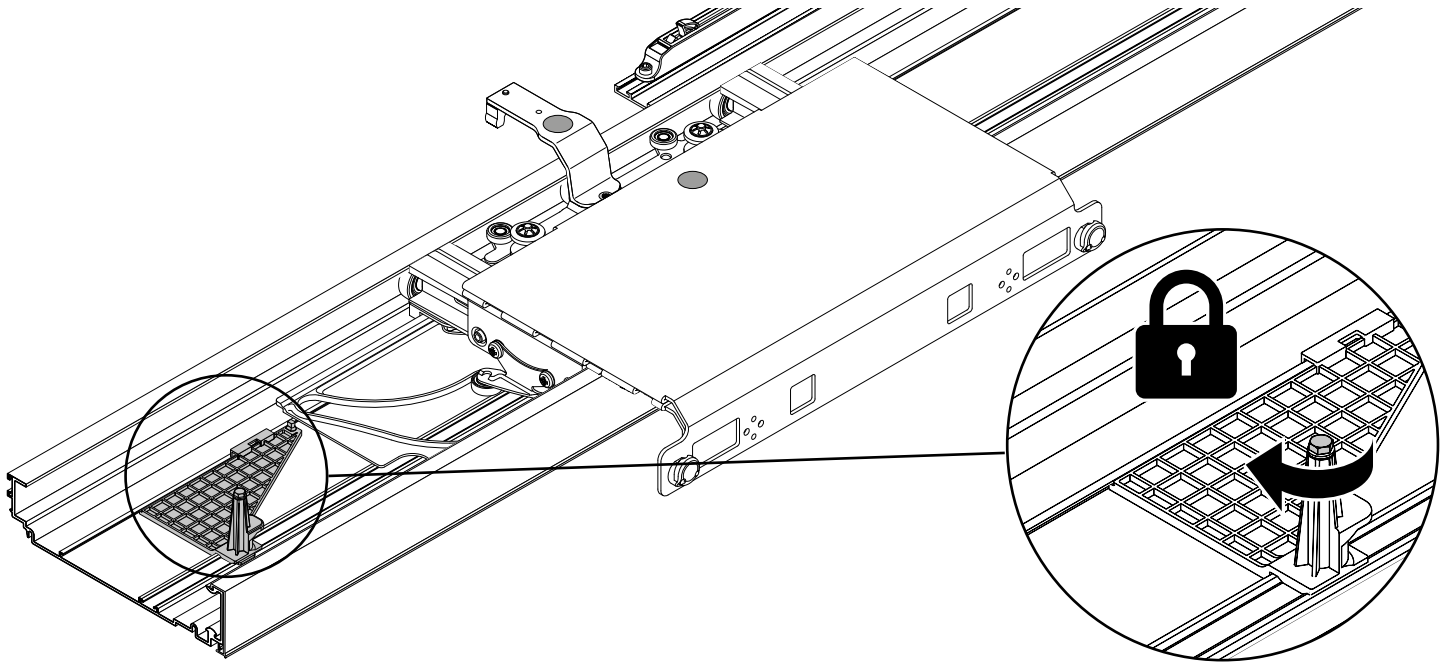

$$d = WA / 2 - S - 400$$

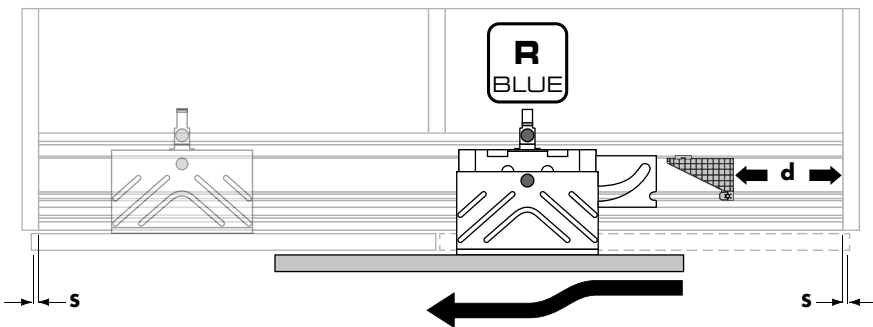
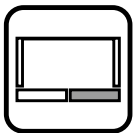

$$d = WA / 2 - S - 400$$

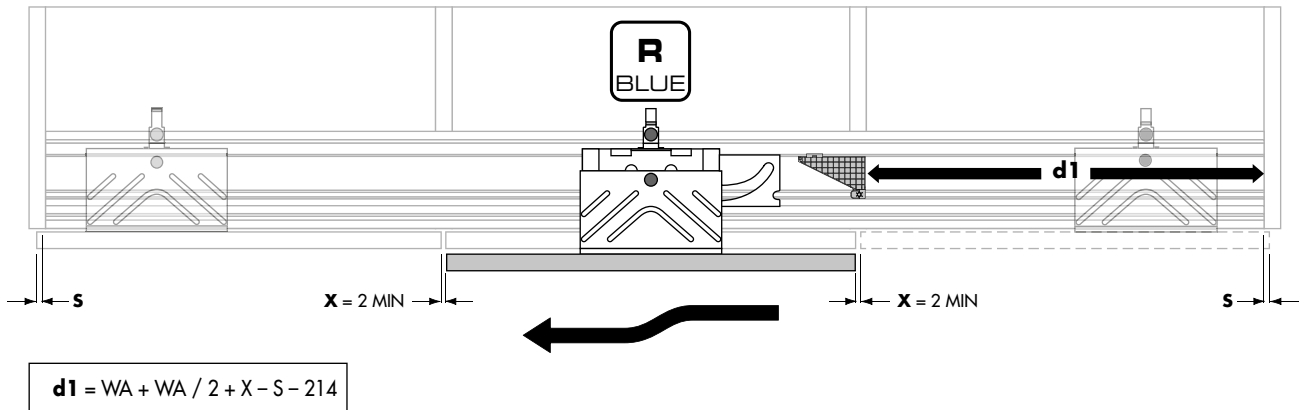
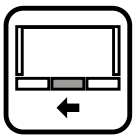
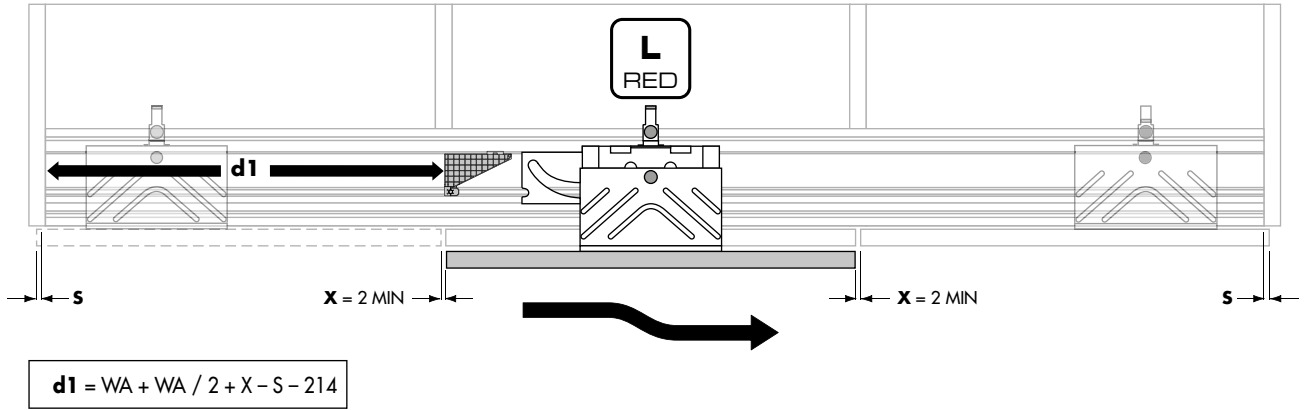
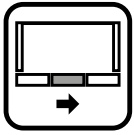
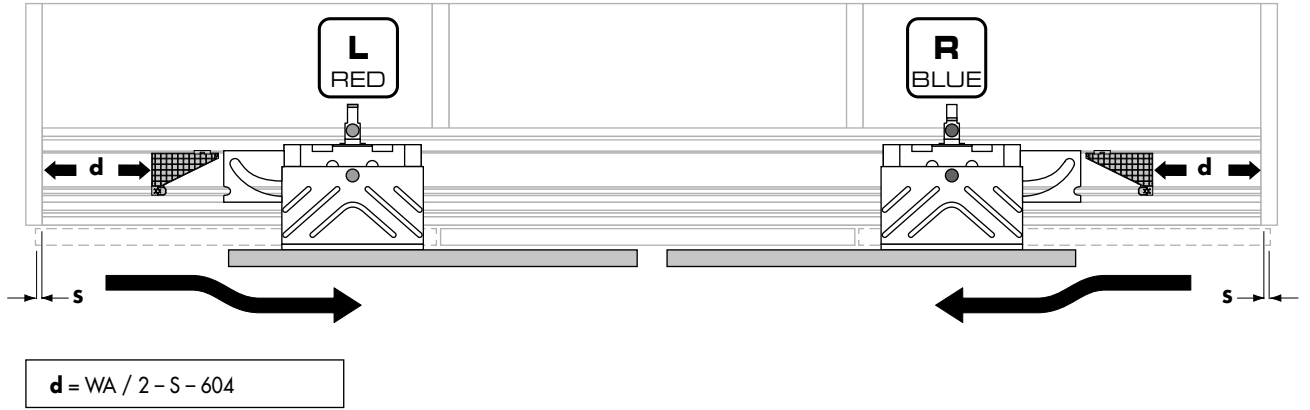
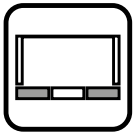



Posizionamento e fissaggio del sistema Softspace in apertura.

Positioning and fixing of the Softspace device in the opening.

Positionnement et fixation de le système Softspace par l'ouverture.

Positionierung und Befestigung des Softspace System.

Posicionamiento y fijación del Sistema de amortiguador Softspace en abertura.

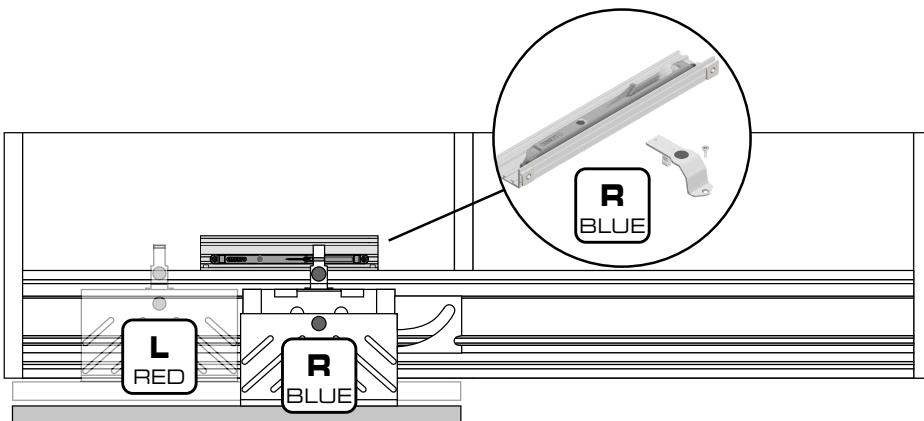
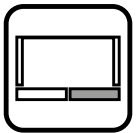
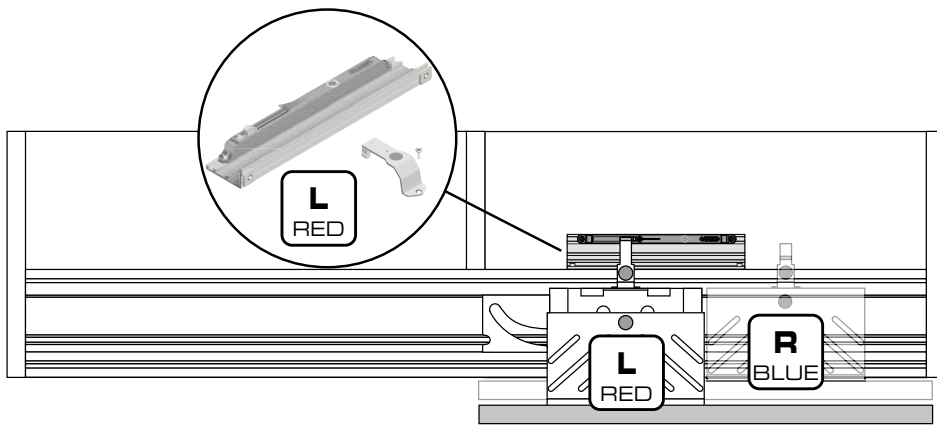
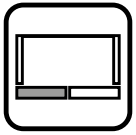
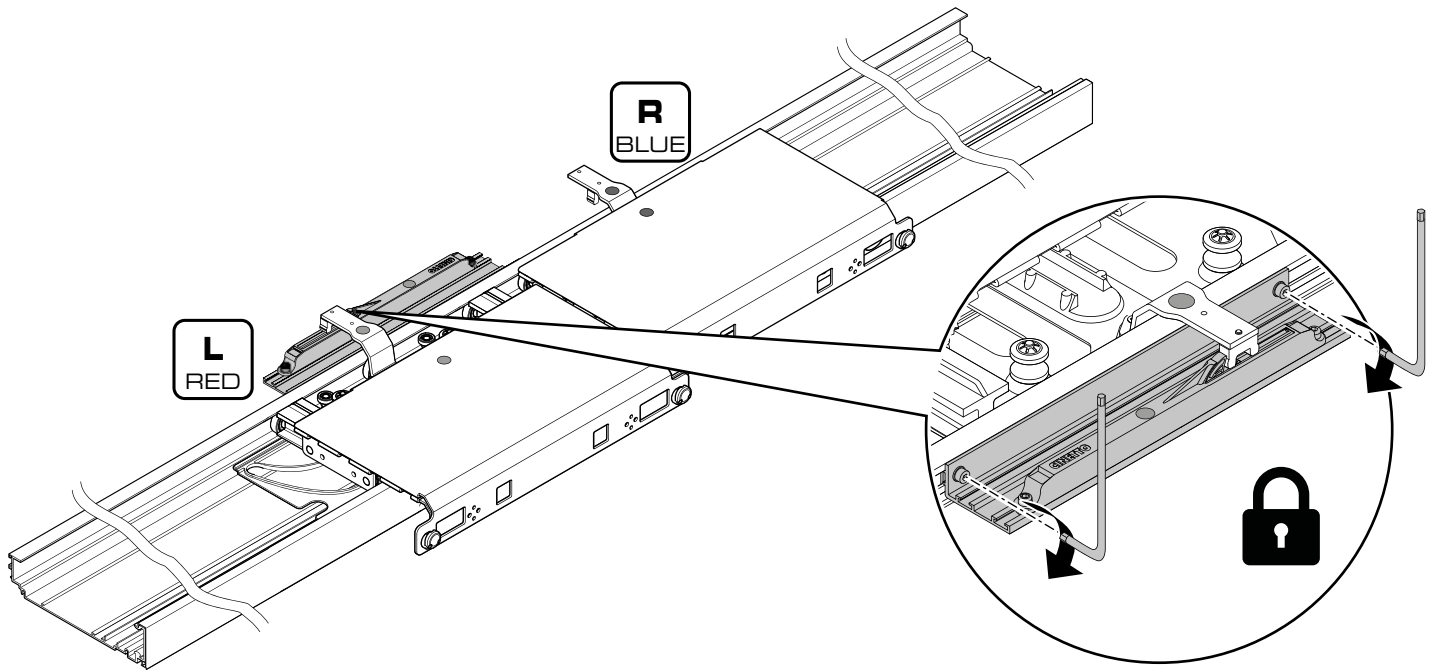

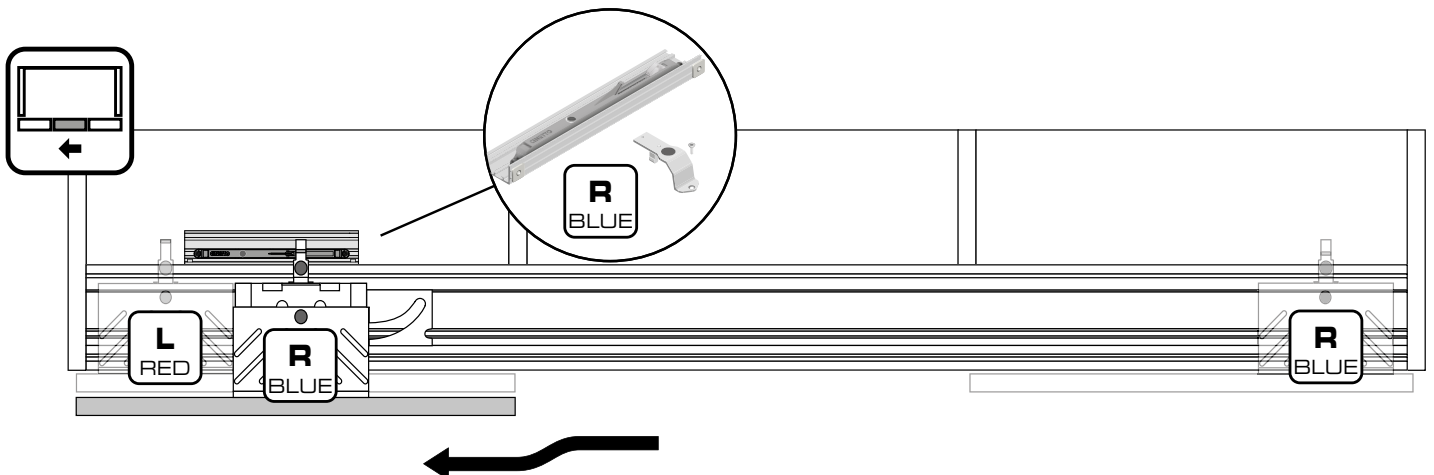
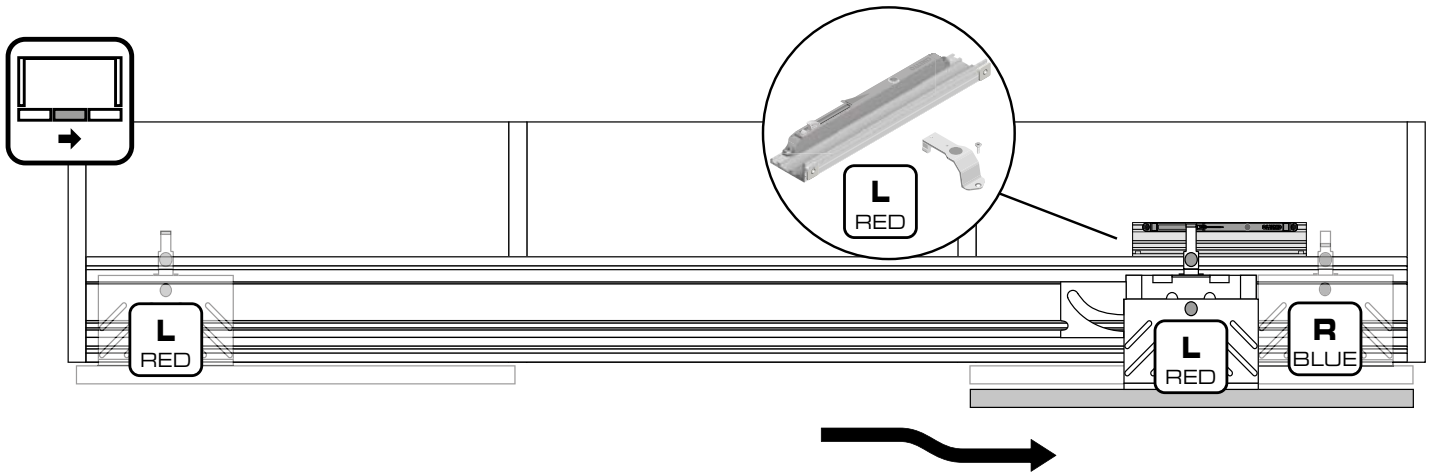
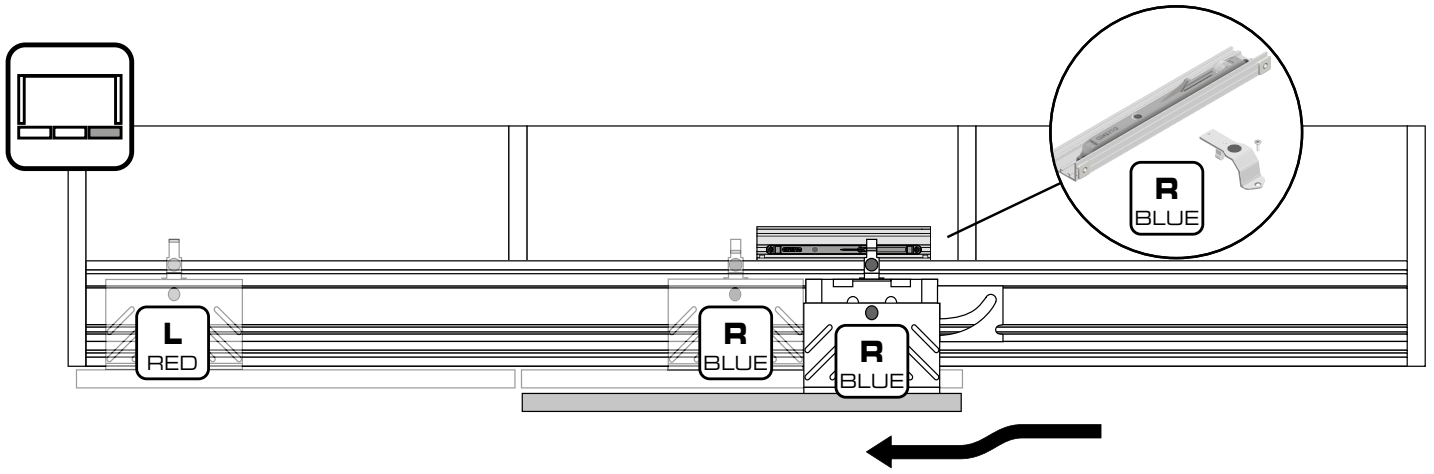
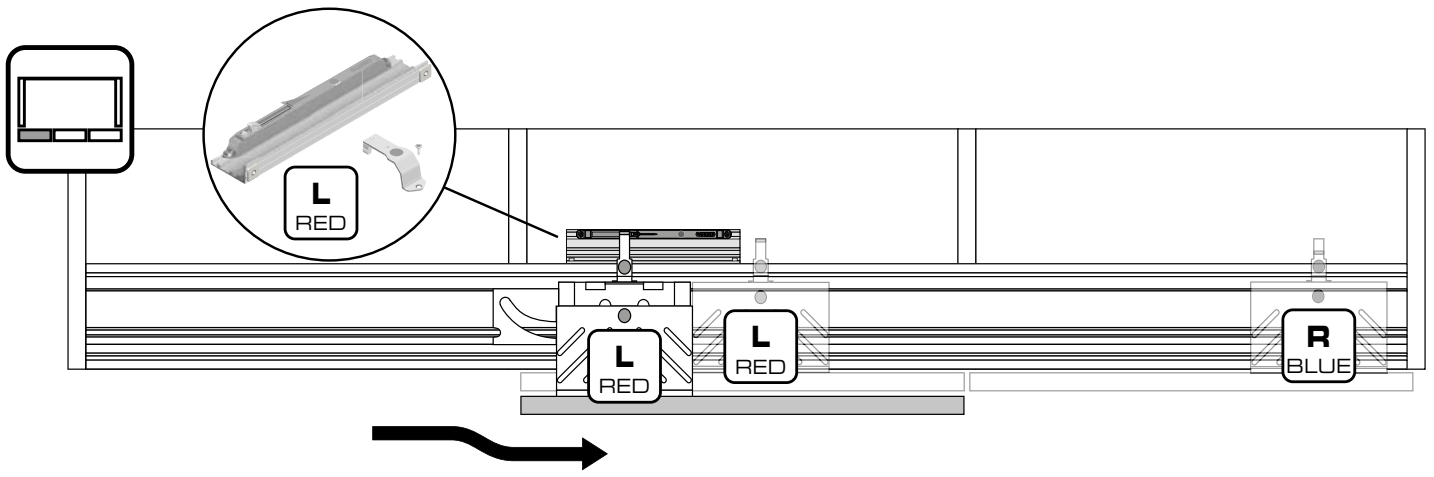

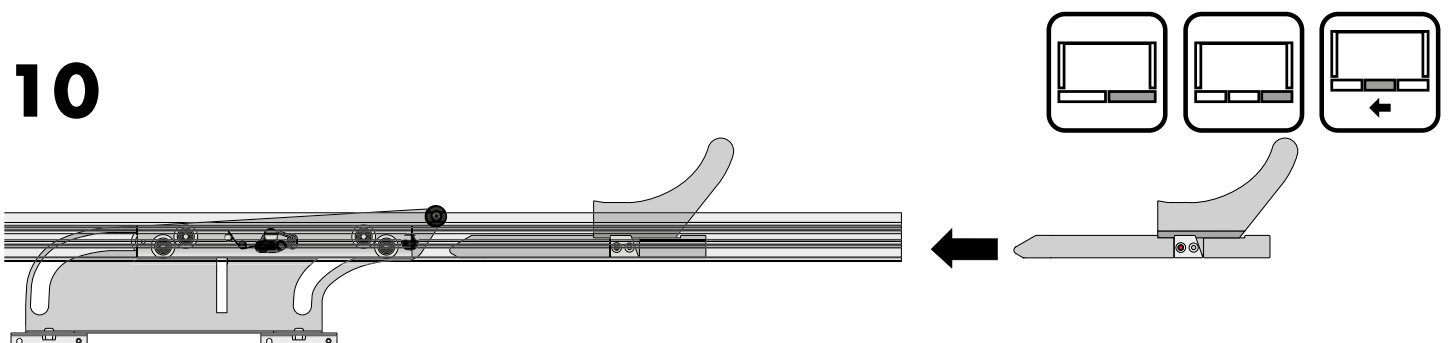
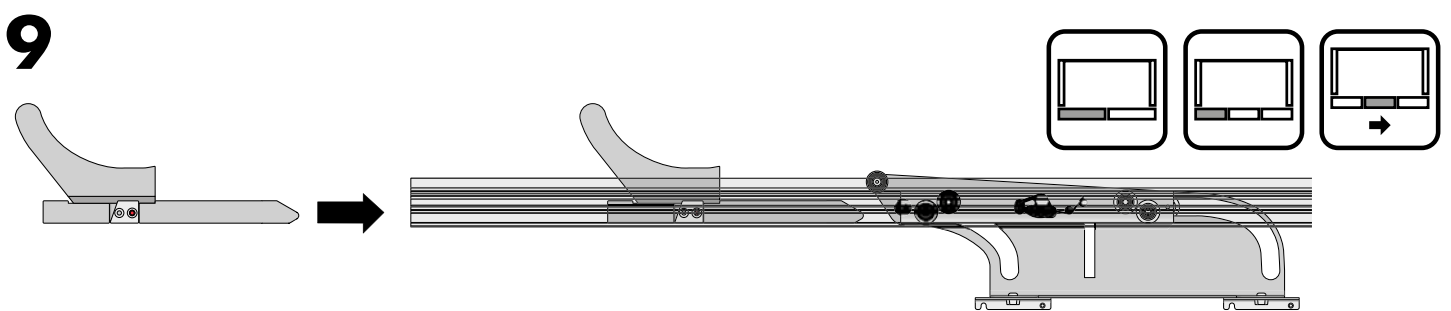
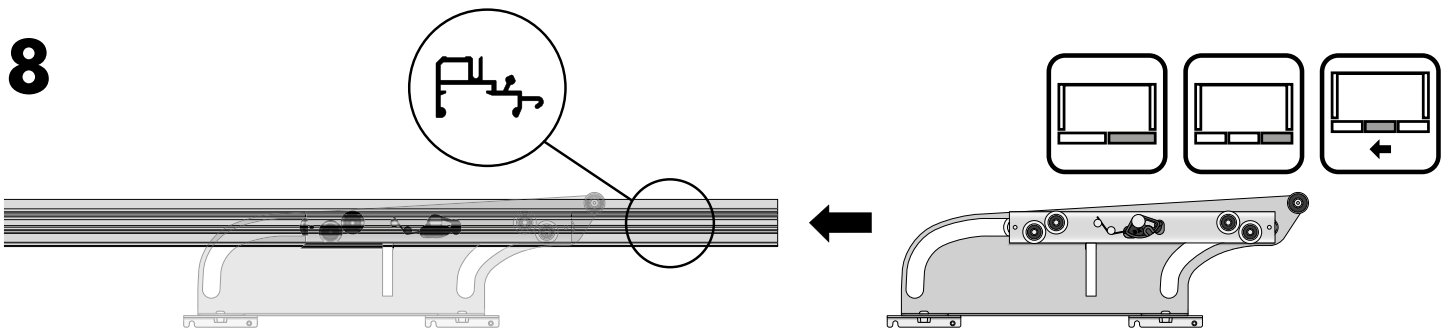
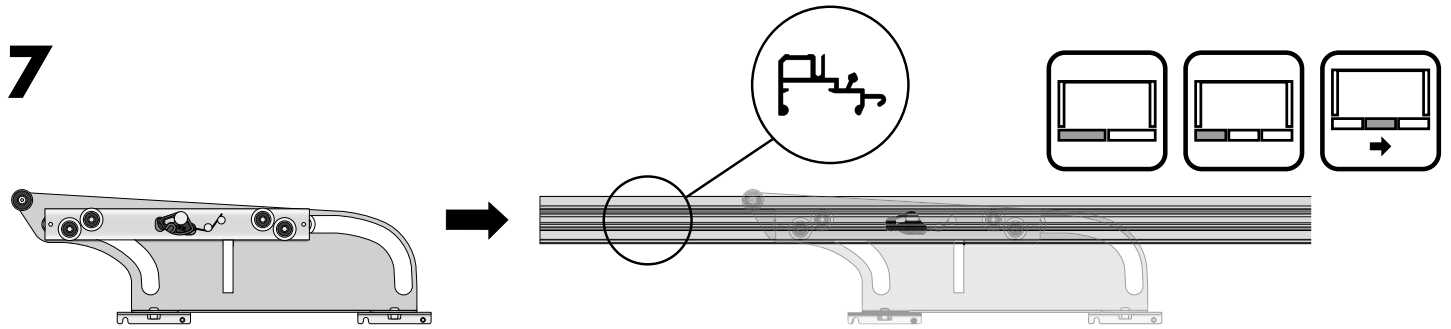
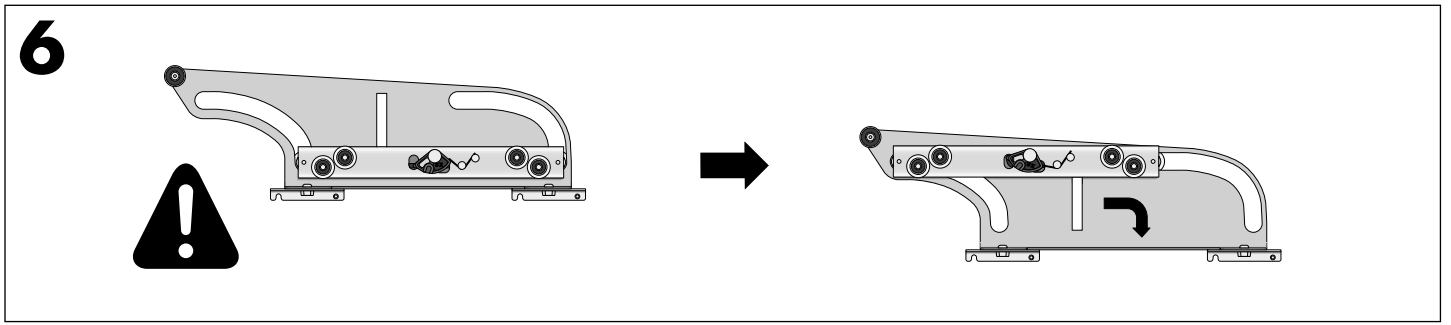



Posizionamento e fissaggio dei fermi inferiori.

Positioning and fixing of the lower locks.

Positionnement et fixation des supports inférieurs.

Positionierung und Befestigung der unteren Aufschläge.

Posicionamiento y fijación de los topes inferiores.

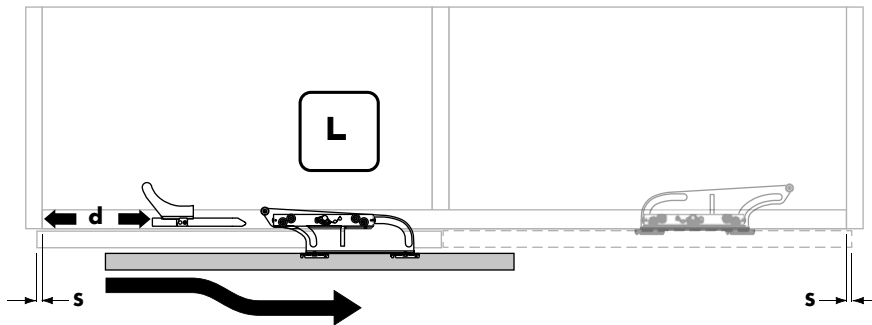
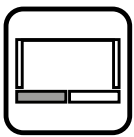
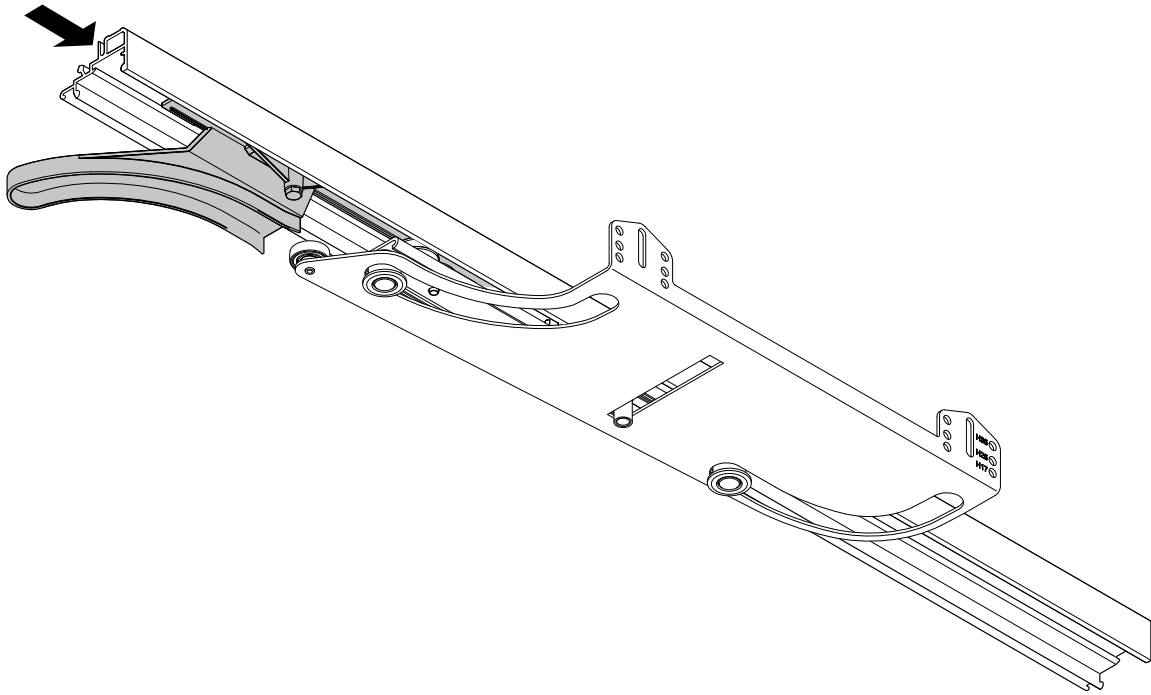

$d = WA / 2 - S - 400$

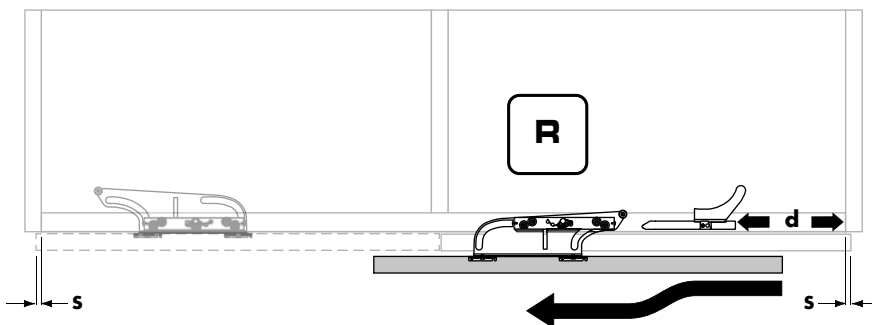
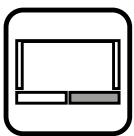

$d = WA / 2 - S - 400$

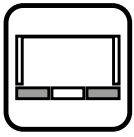

$$d = WA / 2 - S - 604$$

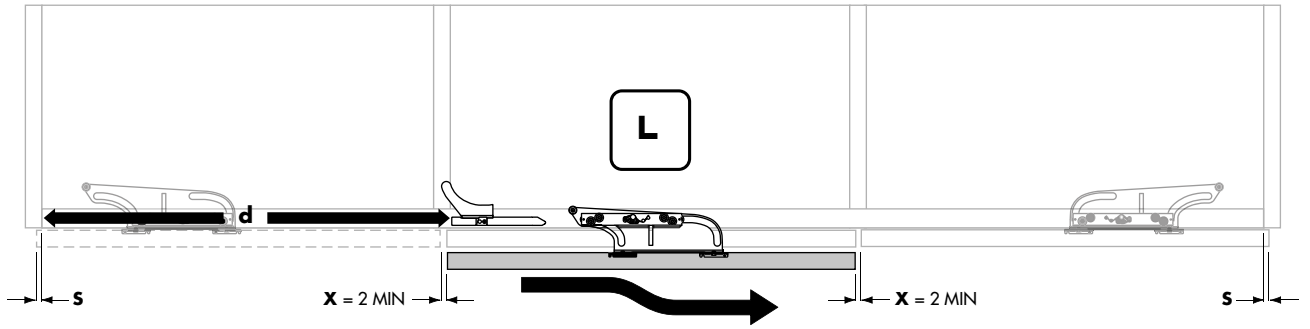
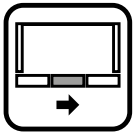

$$d1 = WA + WA / 2 + X - S - 214$$

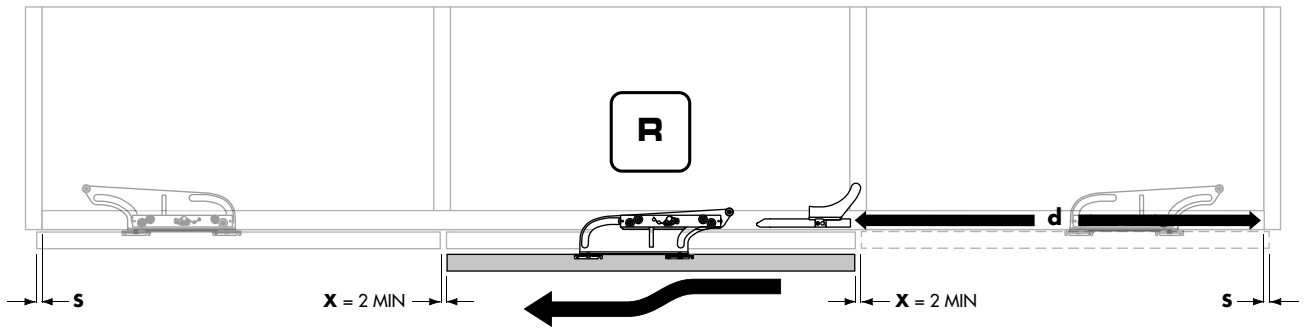
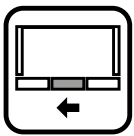

$$d1 = WA + WA / 2 + X - S - 214$$

11

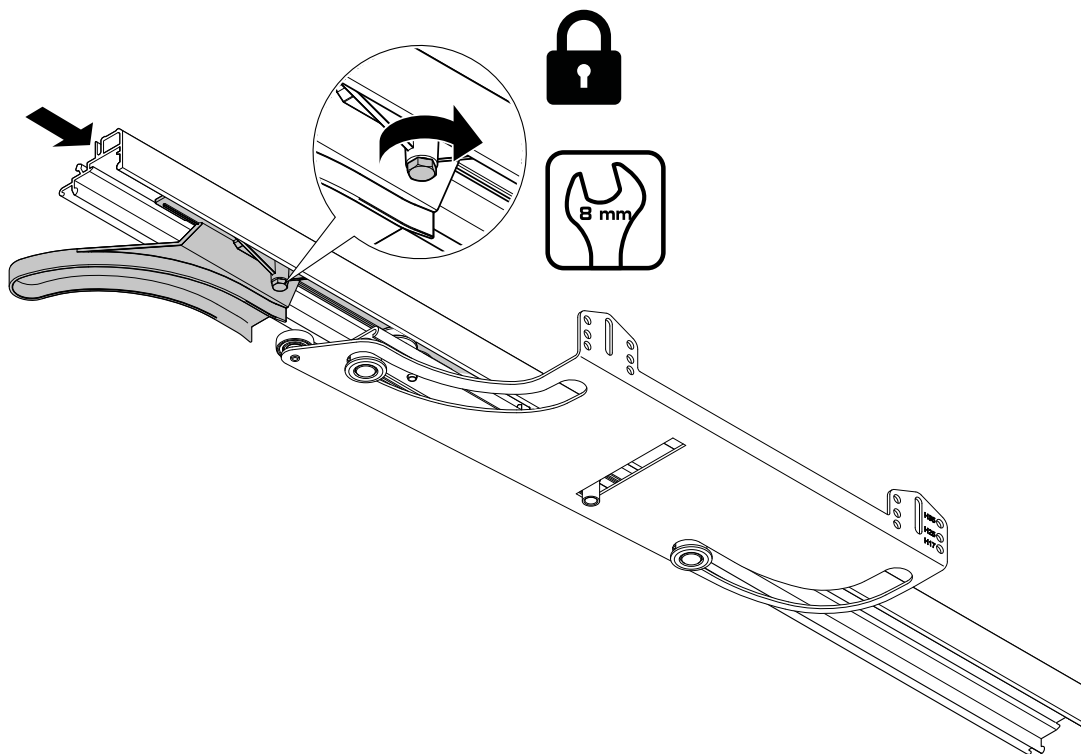

12

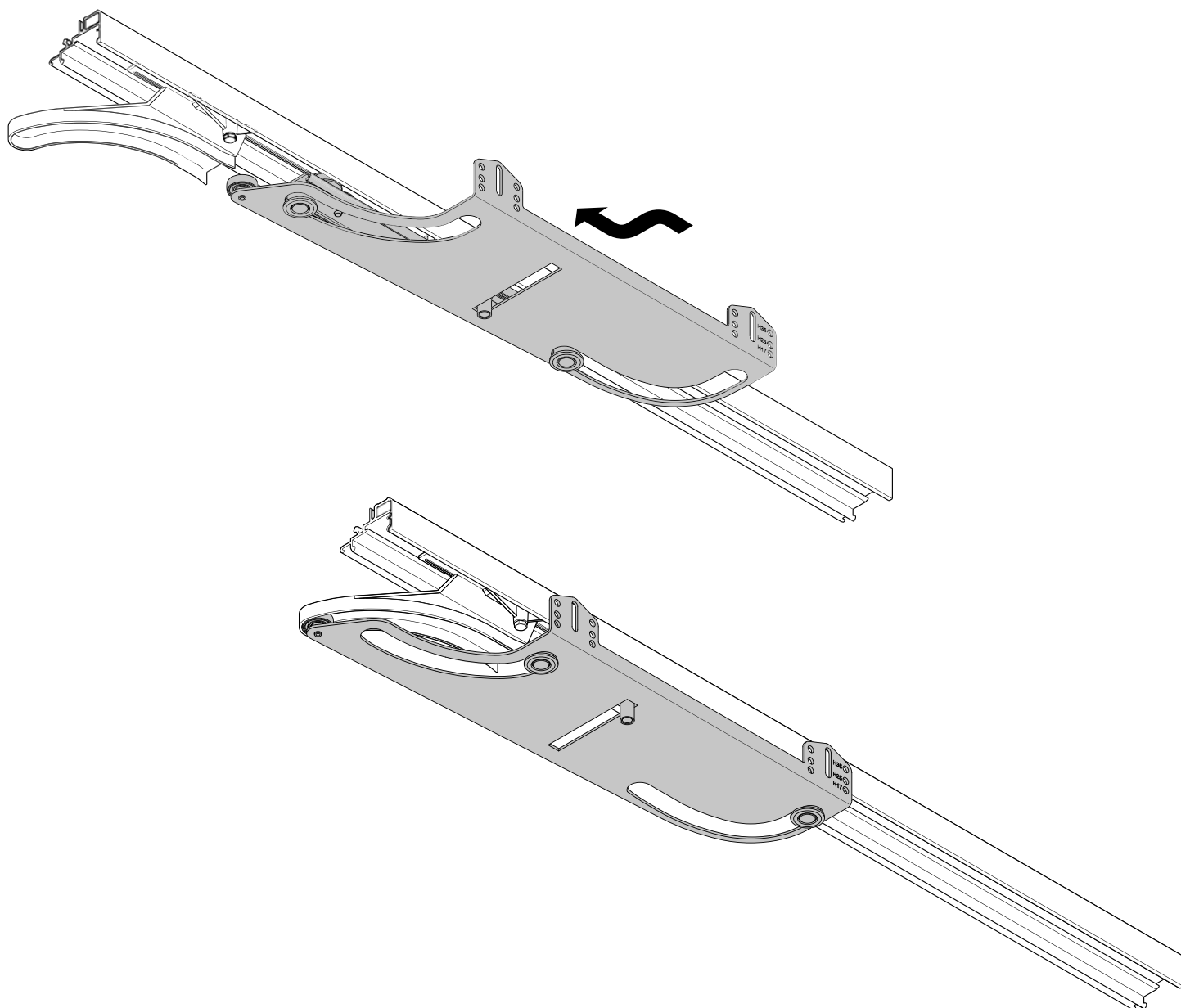

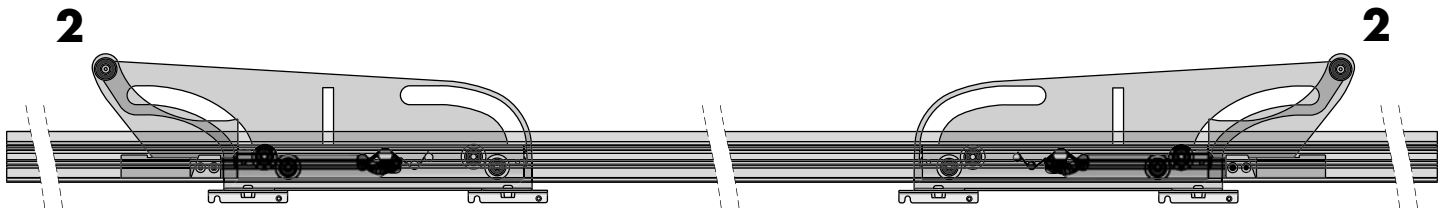
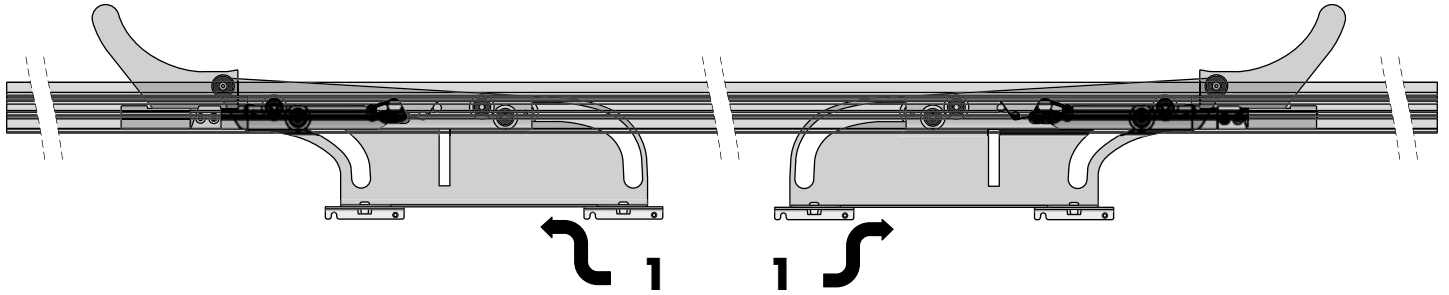

N.B. L'anta deve essere agganciata a pattino chiuso.

N.B. The lower slide must be closed during the door hooking.

N.B. La porte doit être accrocher avec le chariot fermé!

N.B. Der untene Laufwagen muss zu sein, bevor die Tür angehakt wird!

N.B. La puerta debe ser enganchada con el patin cerrado!

13

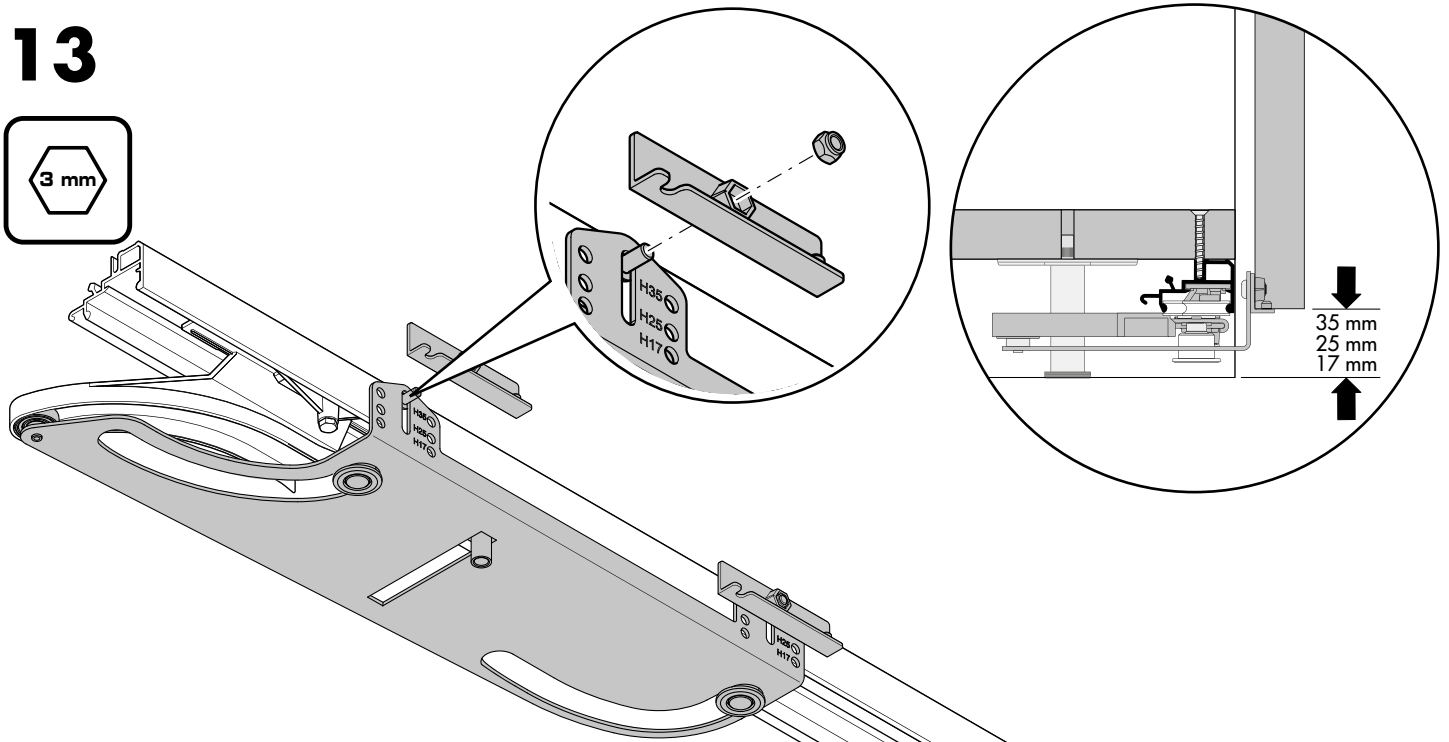

Distanza tra lo spigolo inferiore dell'anta e pavimento (17 mm, 25 mm, 35 mm).

Distance between the door and the floor (17 mm, 25 mm, 35 mm).

Distance entre l'arête inférieure de la porte et le sol (17 mm, 25 mm, 35 mm).

Abstand zwischen der unteren Kante der Tür und den Boden.

Distancia entre el borde inferior de la puerta y el piso.

Fissare i binari al mobile secondo la modalità scelta: 14a, 14b, 14c.

Fix the rails on the wardrobe according to the choice: 14a, 14b, 14c.

Fixer the rails au meuble selon le mode choice: 14a, 14b, 14c.

Die Schienen an den Schrank nach Ihrer Wahl befestigen: 14a, 14b, 14c.

Fijar las guías al mueble según vuestra elección: 14a, 14b, 14c.

14a

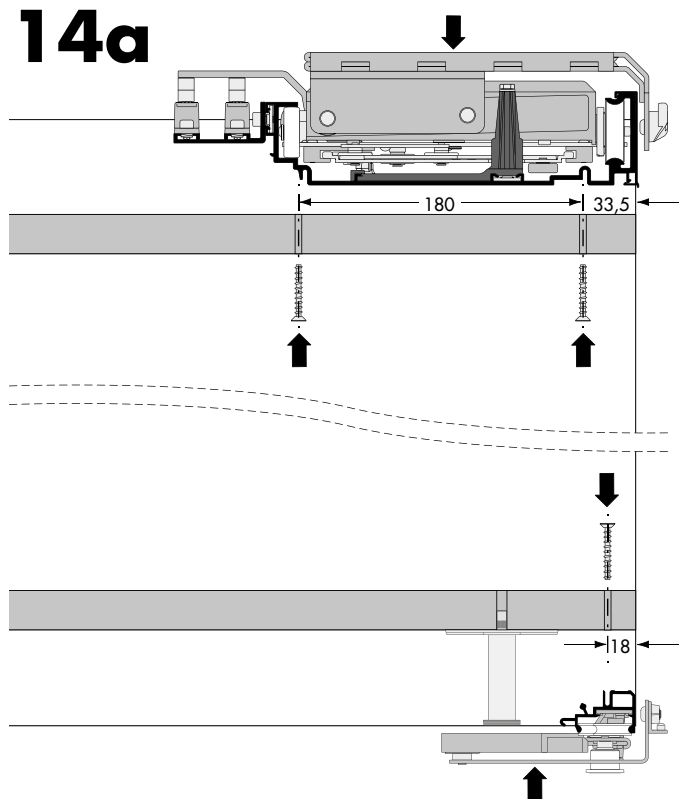

14b

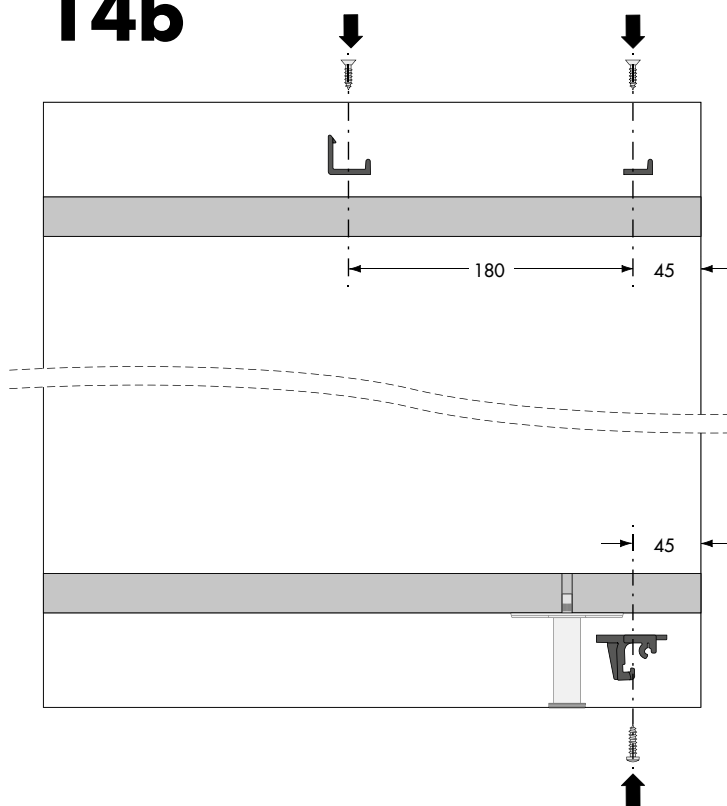

14c

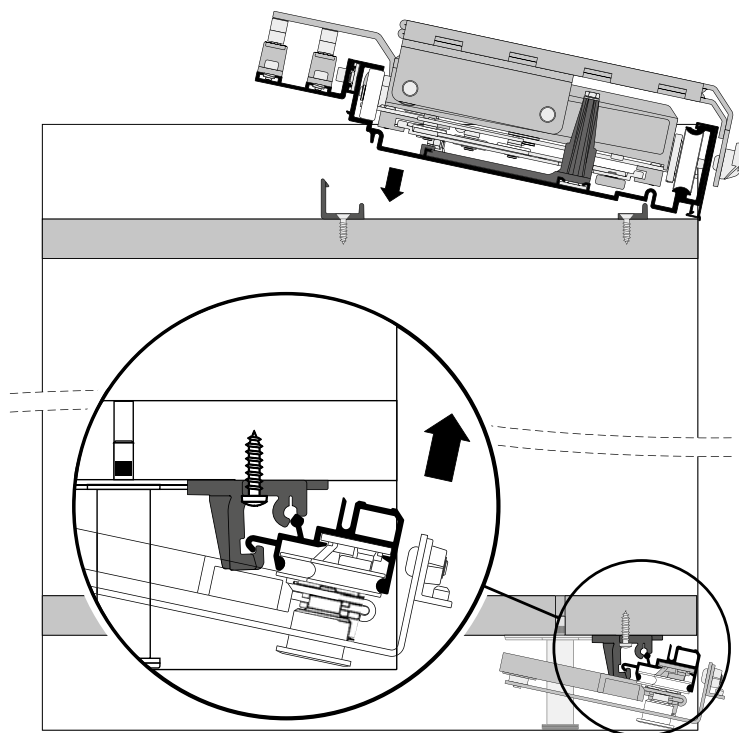
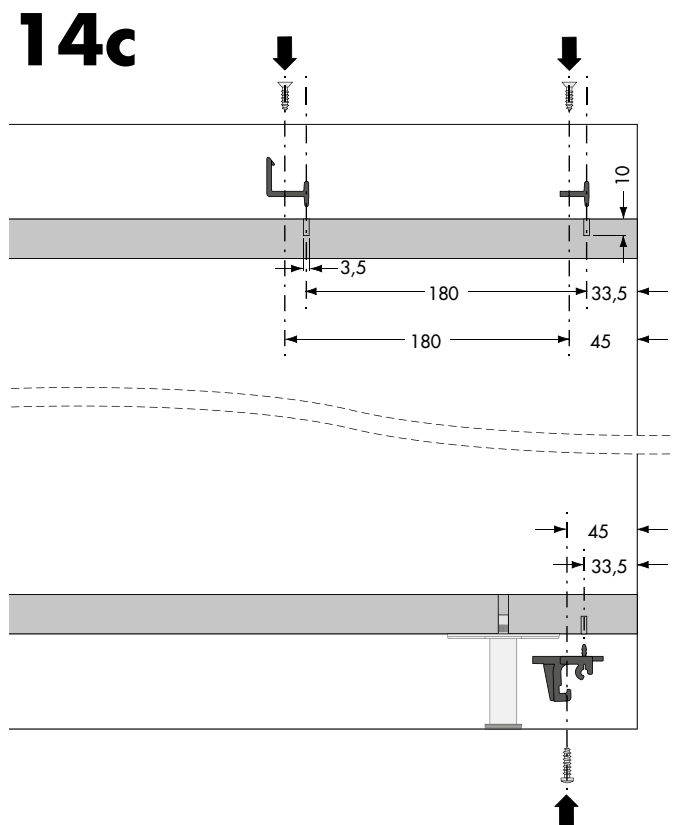

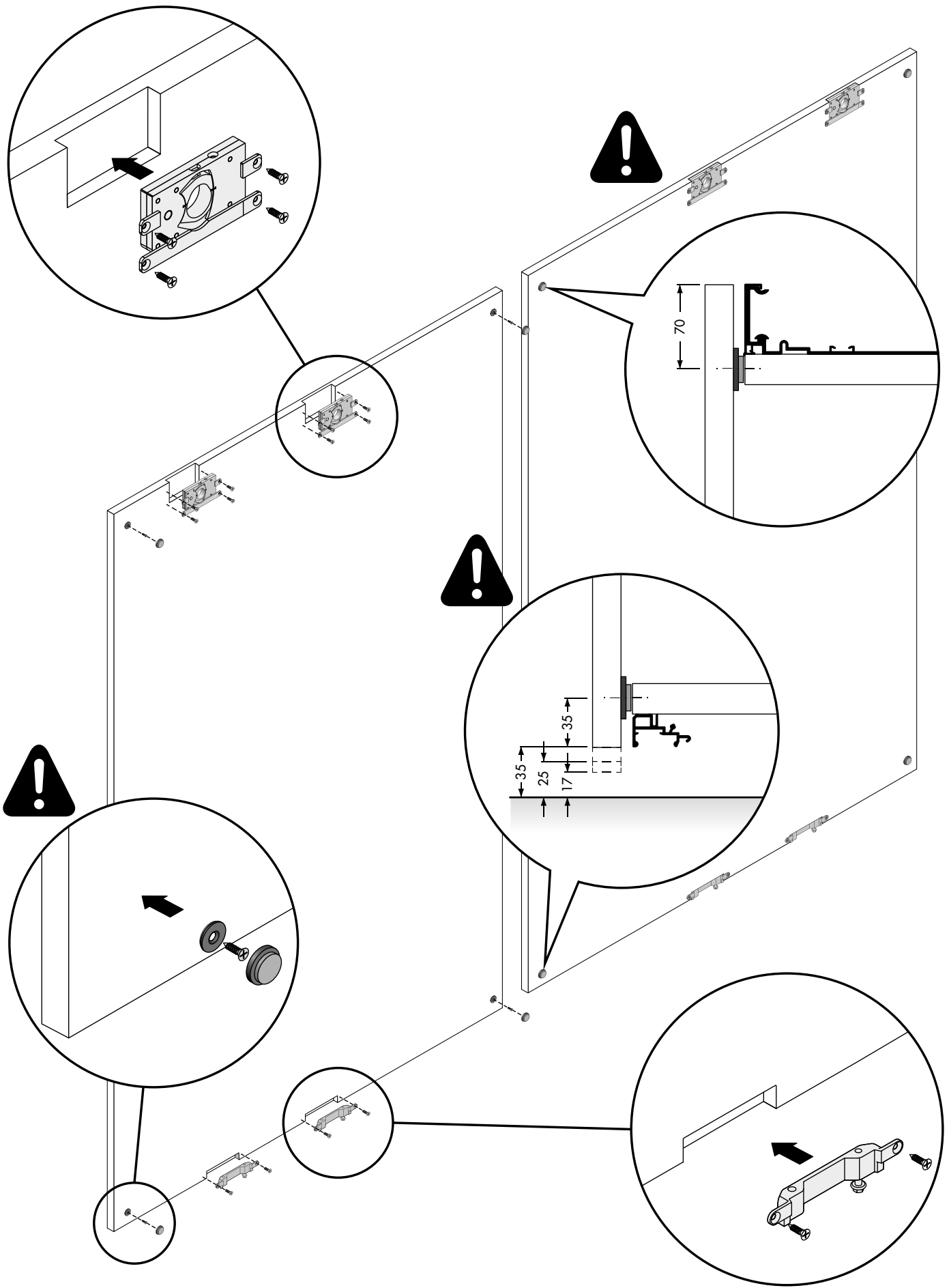

16

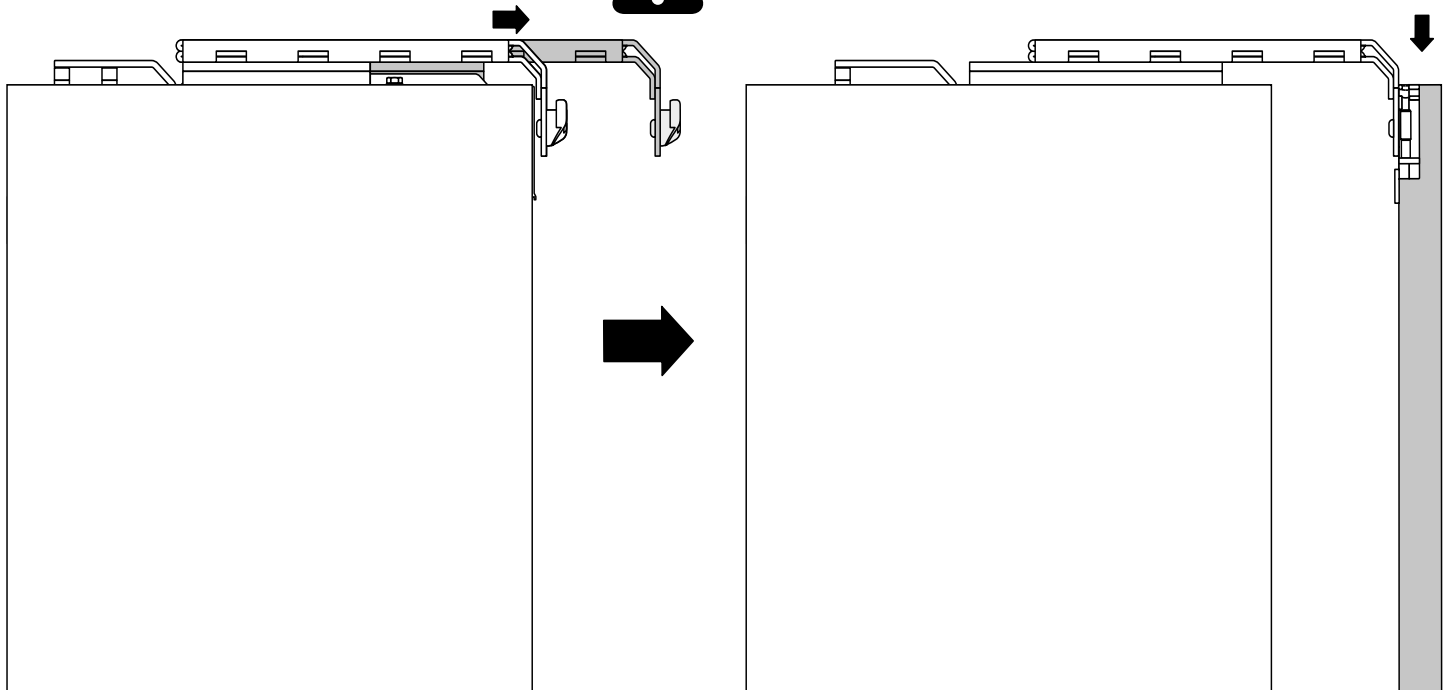

Aprire il pattino superiore prima di appendere l'anta.

Open the upper slide before hanging the door.

Ouvrir le patin supérieur avant d'accrocher la porte.

Öffnen Sie den oberen Laufwagen vor dem Aufhängen der Tür.

Abrir el patin superior antes de colgar la puerta.

17

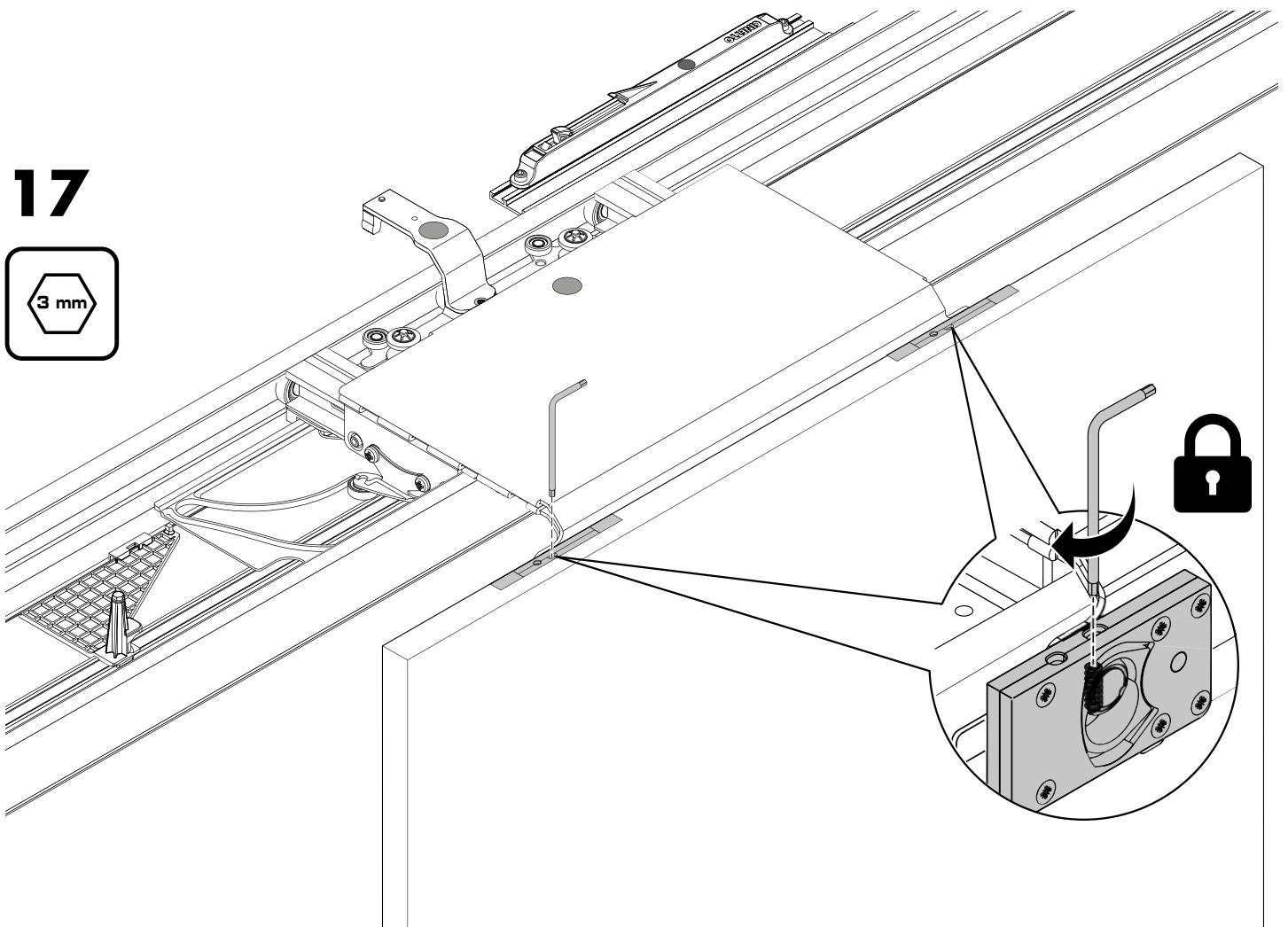

18

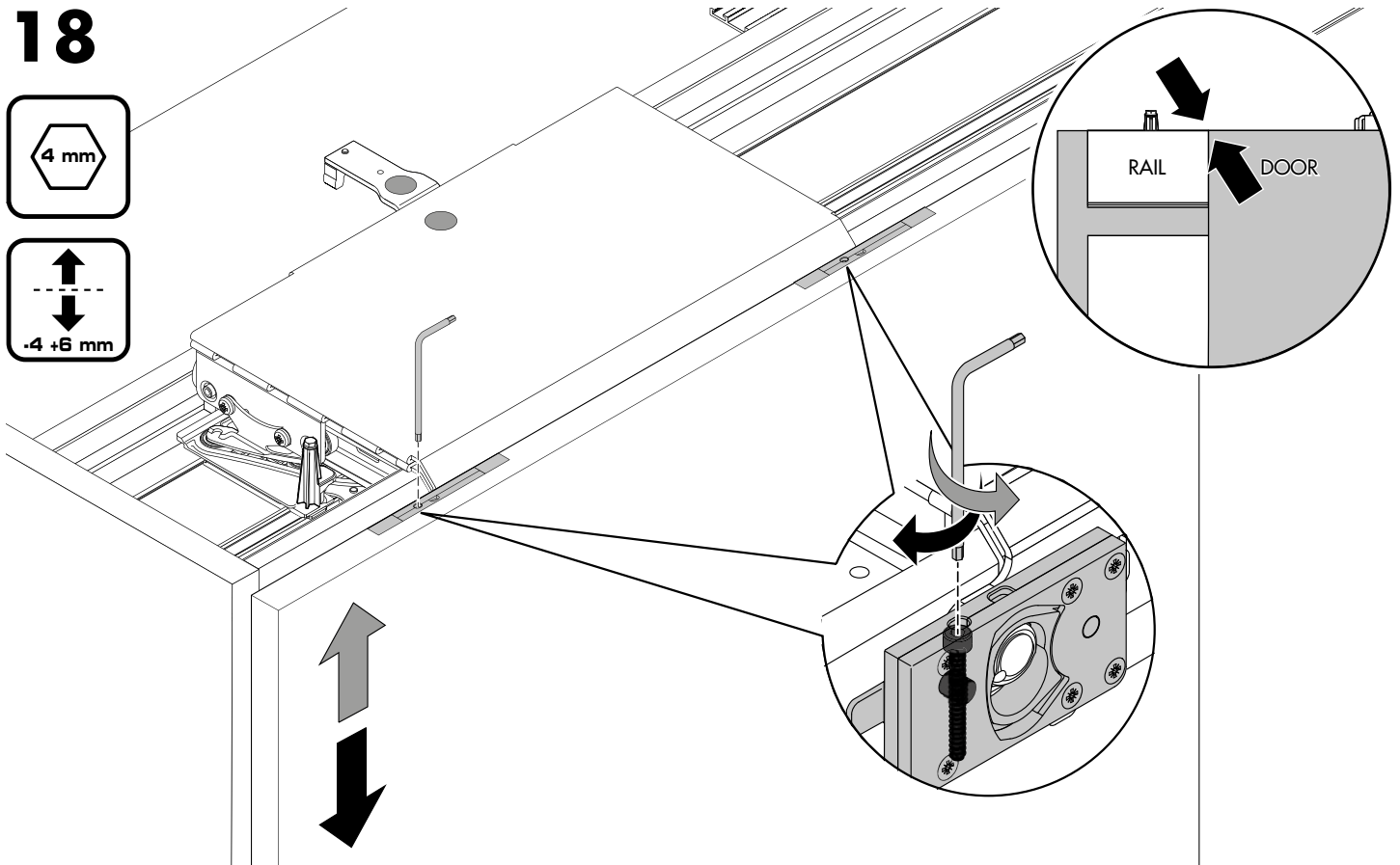

Chiudere l'anta. Regolare il livello dell'anta portandolo a filo del binario superiore.

Close the door. Adjust the level of the door, aligning it with the upper rail.

Fermer la porte. Régler le niveau de la porte en la mettant à ras du rail supérieur.

Schließen Sie die Tür. Stellen Sie die Höhe der Tür und bringen Sie mit der oberen Schiene bündig.

Cerrar la puerta. Ajustar el nivel de la puerta llevándolo a el nivel del perfil superior.

19a

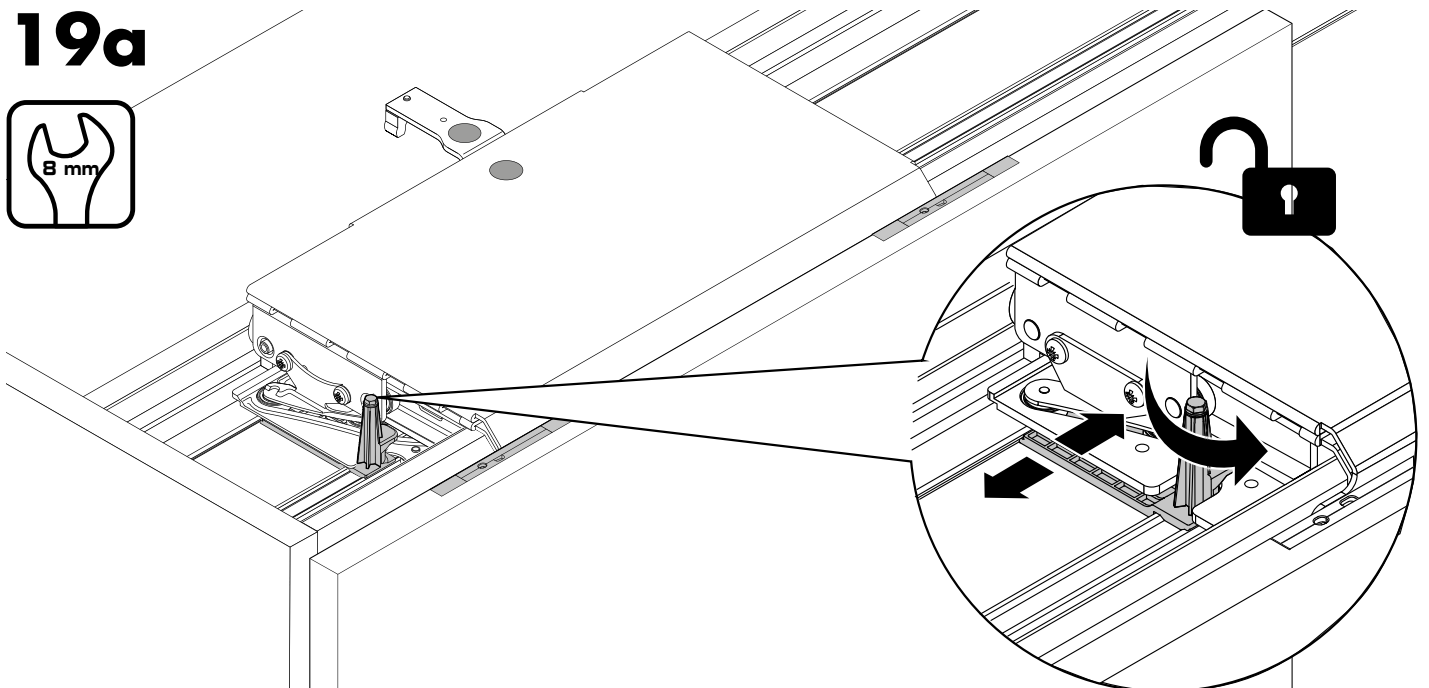

Verificare l'allineamento e la distanza centrale delle ante agendo eventualmente sui fermi superiori.

Check the vertical alignment and the central distance between the doors, eventually move the upper Left or Right locks.

Vérifier l'alignement et la distance centrale des portes en agissant éventuellement sur les butées supérieures.

Überprüfen Sie die Ausrichtung der Türen und der Abstand zwischen die 2 Türe und eventual bewegen Sie die obere Stopper und verstellen noch die Türhoehe.

Comprobar la alineación y la distancia entre las puertas, posiblemente actuando sobre los topes superiores y el ajuste de la puerta.

19b

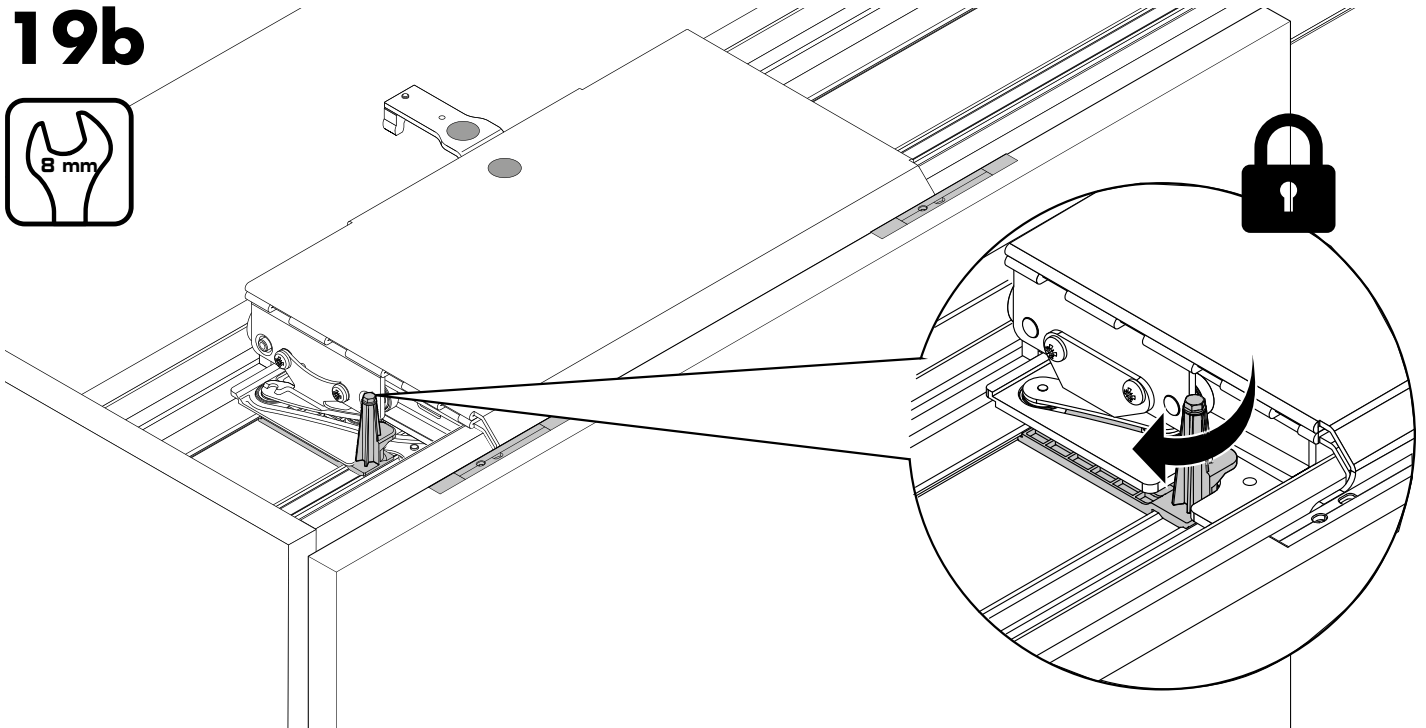

20

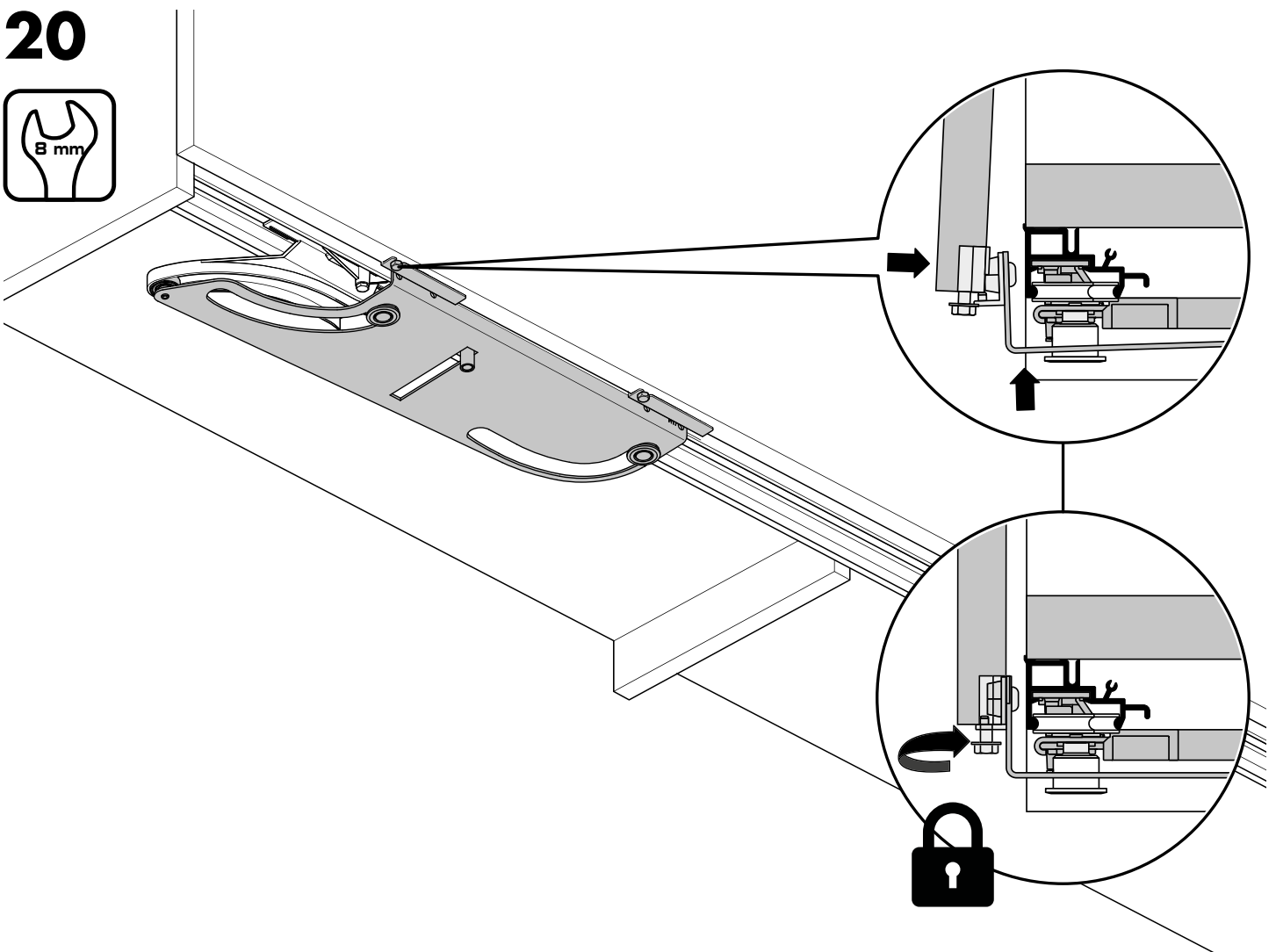

Agganciare il pattino inferiore all'anta e bloccare le viti.

Hook the lower slide and fix the screws.

Accrocher le patin inférieur à la porte et fixer les vis.

Anhaken die untere Führung an der Tür und die Schraube befestigen.

Enganchar el patin inferior a la puerta y fijar el tornillo.



Devi regolare nuovamente l'anta?

Do You need to re-adjust the door?

Devez Vous réajuster la porte?

Müssen Sie die Tür noch wieder justieren?

Es necesario que volver a ajustar la puerta?

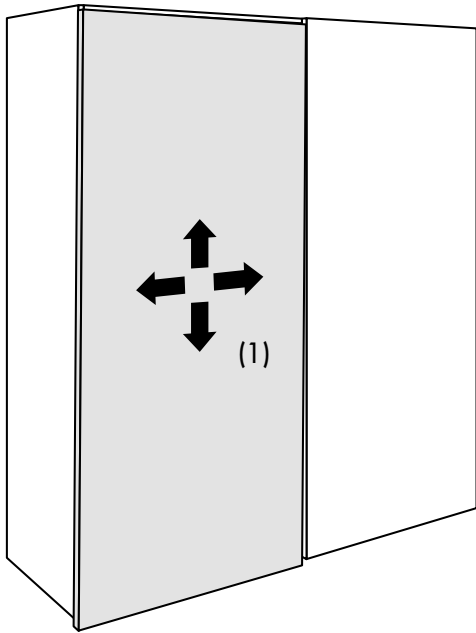

Ricordarsi di sbloccare i fermi inferiori e superiori prima di ulteriori regolazioni delle ante. (1)

Do not forget to unlock the lower and upper stops before any further doors adjustment. (1)

N'oubliez pas de desserrer les butées inférieures et supérieures avant d'effectuer d'autres ajustements des portes. (1)

Bevor weiteren Verstellungen der Türe, vergessen Sie nicht, die unteren und oberen Stopper zu loesen. (1)

No se olvide de desbloquear los topes inferiores y superiores antes de un nuevo ajuste de las puertas. (1)

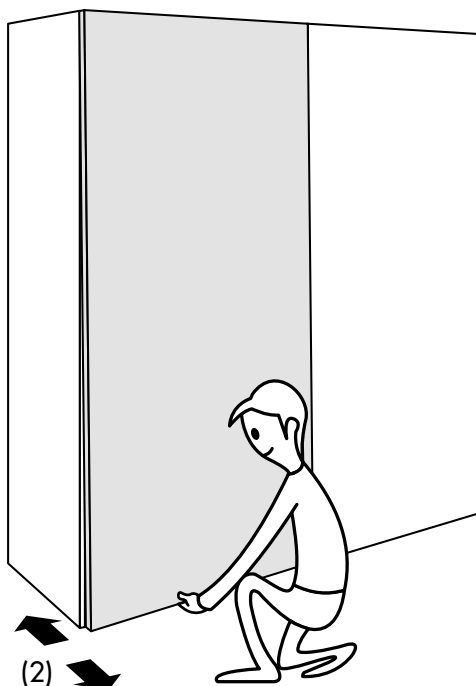
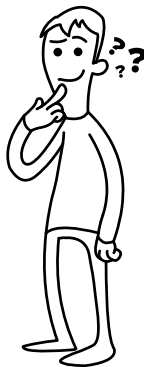

Scuotere (2) leggermente l'anta nella parte inferiore in questo modo lo stop inferiore si allineerà in modo automatico allo stop superiore. Al termine di questa operazione, bloccare nuovamente i fermi.

Slightly shake (2) the door at the bottom with both hands in this way the bottom stop will align automatically to the top stop. Lock the stops when finished.

Basculer (2) doucement la porte au fond de cette manière l'arrêt bas se alignera automatiquement à l'arrêt supérieur. Bloquer les butées après cette opération.

Schwenken Sie (2) die Tür am Ende mit beiden Händen, in dieser Weise die Stop unten wird automatisch auf die Stop oben auszurichten.

Als dieses Verfahren fertig ist, befestigen Sie nochwieder die Stopper.

Agite (2) suavemente la puerta en la parte inferior de esta manera el tope inferior se alineará automáticamente al tope superior. Después de esta operación, re-cerrar los topes.

Come smontare le ante

How to remove the doors

Comment enlever les portes

Wie die Türen entfernen

Cómo quitar las puertas

1

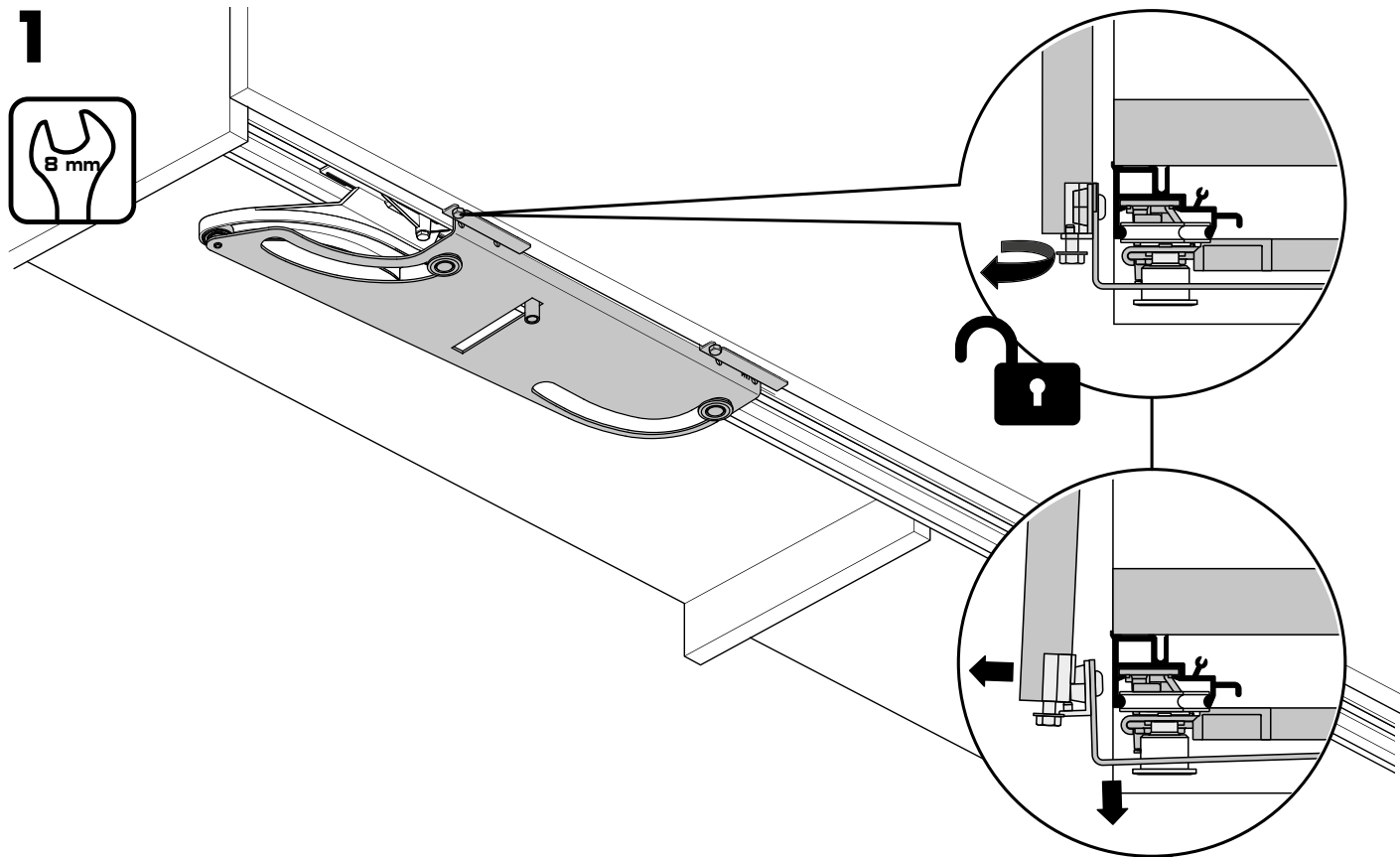

2

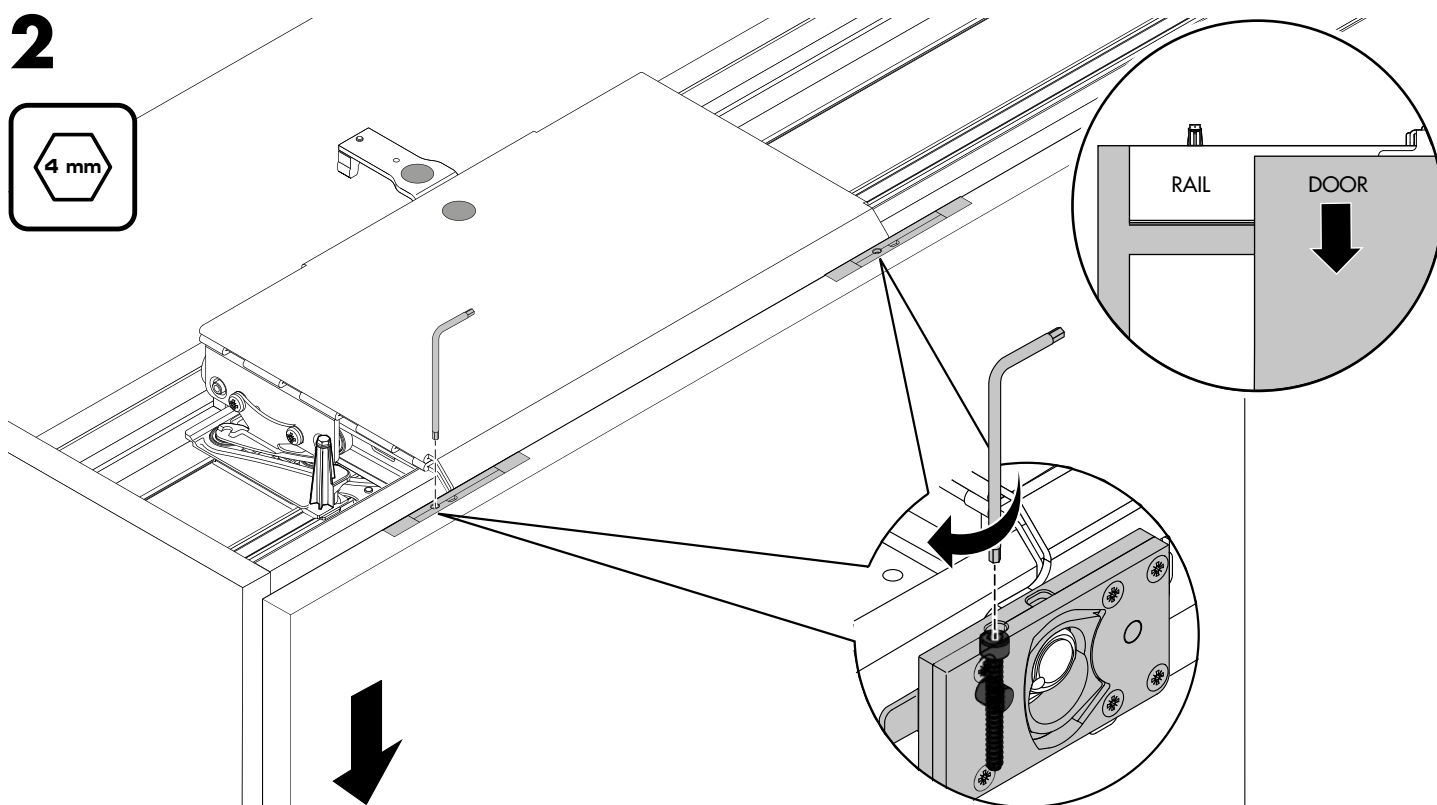

3

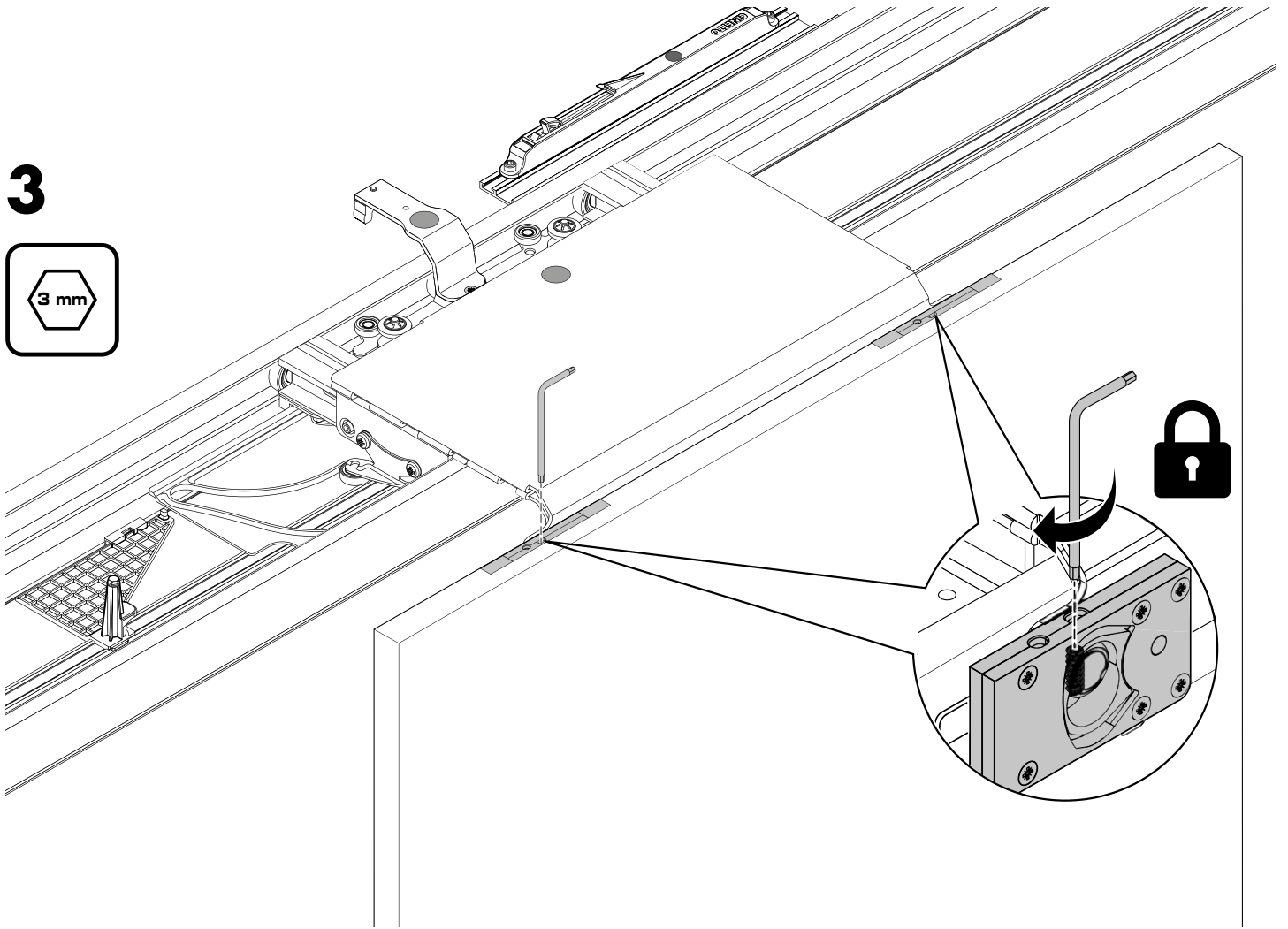

4

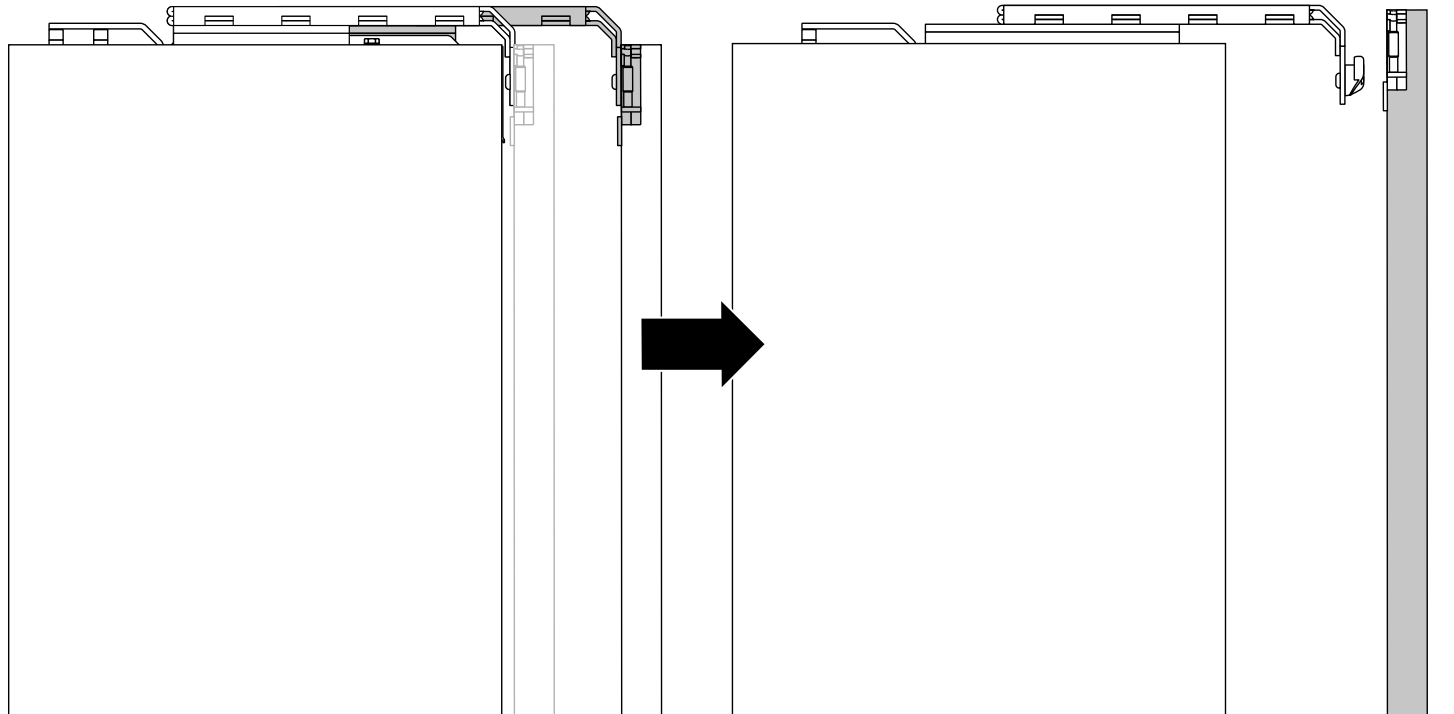

Icone / Icons / Icônes / Icons / Iconos



PS40.1 - ante fresate

PS40.1 - milled doors
PS40.1 - portes fraisées
PS40.1 - Türen ausgefräst
PS40.1 - puertas mecanizadas

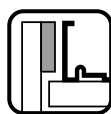

PS40.2 - ante non fresate

PS40.2 - not milled doors
PS40.2 - portes pas fraisées
PS40.2 - Türen nicht ausgefräst
PS40.2 - Puertas no mecanizada



Armadio con 2 ante complanari

2 doors coplanar wardrobe
Armoire avec 2 portes complanaires
Schrank mit 2 flachbündigen Türen
Armario con 2 puertas conplanarias



Armadio con 3 ante complanari

3 doors coplanar wardrobe
Armoire avec 3 portes complanaires
Schrank mit 3 flachbündigen Türen
Armario con 3 puertas conplanarias



Ante a ridosso

Front doors
Portes avant
Fronttüren
Puertas frontales



Ante in luce

Inside doors
Portes intérieures
Innentüren
Puertas interiores



Anta sinistra

Left door
Porte gauche
Linke Tür
Puerta izquierda



Anta destra

Right door
Porte droite
Rechte Tür
Puerta derecha



Apertura anta centrale verso destra

Opening direction of the central door to the right
Sens d'ouverture de la porte centrale vers la droite
Öffnungsrichtung der zentralen Tür rechts
Dirección de apertura de la puerta central a la derecha

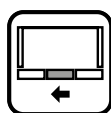

Apertura anta centrale verso sinistra

Opening direction of the central door to the left
Sens d'ouverture de la porte centrale vers la gauche
Öffnungsrichtung der zentralen Tür links
Dirección de apertura de la puerta central a l'izquierda



Sistema di ammortizzazione

Soft-closing device
Système d'amortissement
Dämpfungssystem
Sistema de amortización

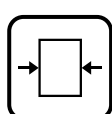

Larghezza anta

Door width
Largeur de la porte
Türbreite
Puerta de ancho

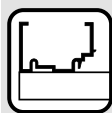

Binario superiore

Upper rail
Rail supérieur
Obere Schiene
Perfil superior



Binario inferiore

Lower rail
Rail inférieur
Untere Schiene
Perfil inferior



Chiave a forchetta

Fork wrench
Clé à fourche
Gabelschlüssel
Llave inglesa

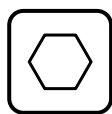

Chiave esagonale

Allen-key
Clé hexagonale
Sechskantenschlüssel
Llave hexagonal

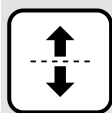

Regolazione verticale

Vertical adjustment
Ajustement vertical
Höhenverstellung
Regulación vertical



Destro

Right
Droite
Rechts
Derecho



Sinistro

Left
Gauche
Links
Izquierda



Consultare capitolo / pagina

See chapter / page
Consulter chapitre/page
Siehe Kapitel / Seite
Consulte el capítulo/página

